



# Expert Pro Series User Manual



<http://www.GCCworld.com>

## **NOTICE**

GCC reserves the right to modify the information contained in this user manual at any time without prior notice; un-authorized modification, copying distribution or display is prohibited. All comments, queries or suggestions concerning this manual please consult with your local dealer.

## Important Information

Thanks for your purchase of GCC *Expert Pro* Cutting Plotter. For your safety and to optimize the performance of the Expert Pro, please read the user manual completely and keep it in a correct location.

### PRECAUTIONS IN USE

- For safety concern, please always hold the cutter firmly **from the bottom** when moving it. Do not move the cutter by clasping the depression area on both sides.

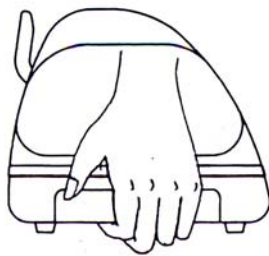

(O)

hold from the bottom

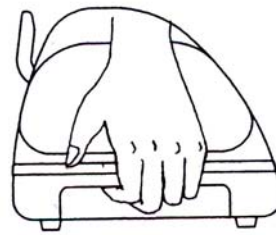

(X)

hold the depression area

- Do not shake or drop the blade holder, a blade tip may fly out.
- During operation, keep away from any moving parts of the cutter (such as the carriage, drums). Also be careful that your clothing and hairs do not be caught.
- Always connect the power cable to a grounded outlet.
- Always use the accessory power cable that is provided. Do not wire the power cable so that it becomes bent or caught between objects.
- Do not connect the power cable to branching outlet to which other machines are also connected, or use an extension cable. There is danger of overheating and of misoperation of the machine.
- Keep the tools away from children where they can reach.
- Always put the pinch rollers within position of the white marks.

# Contents

## Important Information

### 1. General Information

1.1	Introduction	1-1
1.2	Package Items	1-1
1.3	Product Features	1-2
1.4	Appearance of Expert Pro	1-3
1.4.1	Front View of Expert Pro	1-4
1.4.2	Back View of Expert Pro	1-4
1.4.3	The Whole View of Expert Pro	1-4
1.4.4	The Left-hand Side of Expert Pro	1-5
1.4.5	The Right-hand Side of Expert Pro	1-5

### 2. Installation

2.1	Precaution	2-1
2.2	Stand & Flexible Media Support System	2-2
2.2.1	Stand Installation (for EP-60)	2-2
2.2.2	Stand & Flexible Media Support System (for EP-132S)	2-5
2.3	Blade Installation	2-9
2.4	Cable Connections	2-12
2.4.1	USB Interface	2-12
2.4.2	Parallel Interface	2-16
2.4.3	RS-232 Interface	2-16
2.4.4	Data Transmitting	2-16

### 3. The Control Panel

3.1	The LCD Panel	3-1
3.2	Menu in On-line Mode	3-2
3.3	Menu in Off-line Mode	3-3
3.4	Menu Items	3-4

### 4. Operation

4.1	Media Loading	4-1
4.1.1	Loading the Sheet Media	4-1
4.1.2	Loading the Roll Media	4-3
4.2	Tracking Performance	4-6
4.3	Cutting Force and Offset Adjustment	4-7
4.4	When Completing the Cutting Job	4-9

### 5. Maintenance

5.1	Cleaning the cutting Plotter	5-1
5.2	Cleaning the Grid Drum	5-2
5.3	Cleaning the Pinch Rollers	5-2

### 6. Trouble Shooting

6.1	Non-Operational Problems	6-1
6.2	Operational Problems	6-2
6.3	Communication Problems	6-3
6.4	Software Problems	6-4

6.5 Cutting Quality Problems 6-5

**Appendix**

A-1 Specifications of Puma II Plus A-1  
A-2 Blade Specification A-2

# Chapter 1 General Information

## 1.1 Introduction

Expert Pro series cutting plotters have been designed to produce computer-generated images on sheets or rolls of vinyl media.

This manual covers the following models of Expert Pro series cutting plotters:

• EP-60	for media width: 70mm(2.76") ~ 719mm(28.3")
• EP-132S	for media width: 70mm(2.76") ~ 1470mm(57.87")

## 1.2 Package Items

The package of the Expert Pro model contents the items listed below, please check carefully. If you find any item missing, please consult your local dealer for further assistance.

Standard Item	Quantity
<b>1. Cutting Plotter</b>	<b>1</b>
<b>2. Stand Set ( for EP-60 )</b> <ul style="list-style-type: none"> <li>● 1 Left side vertical stand</li> <li>● 1 Right side vertical stand</li> <li>● 1 Support for left side</li> <li>● 1 Support for right side</li> <li>● 1 Stand Beam</li> <li>● 2 Bottom Stands with wheels</li> <li>● 2 Sliding brackets for paper takeup</li> <li>● 1 Hex Wrench (M5)Φ4</li> <li>● 28 Socket flat head screws(M6*12L)</li> <li>● 1 Installation Guide</li> </ul>	<b>1</b>
<b>2. Stand Set ( for EP-132S )</b> <ul style="list-style-type: none"> <li>● 2 piece of T-shape stand</li> <li>● 1 piece of stand beam</li> <li>● 18 pieces of M6 screws</li> <li>● 1 piece of M5 L-shape hexagon screw driver</li> <li>● 1 piece of Installation Guide for Stand Set</li> </ul>	<b>1</b>

<b>3. Flexible Media Support System Package</b>			<b>1</b>
Items	EP-60	EP-132S	
1 set of Roll Media Flange (2 pieces)		✓	
1 set of Roll Holder (2 pieces)		✓	
1 set of Roll Holder Guide Bushes (4 pieces)		✓	
1 set of Roll Holder Support (2 pieces)		✓	
32 pieces of M6 screws		✓	
1 piece of M6 L-shape hexagon screw driver		✓	
1 piece of Roll Base	✓		
<b>4. Accessories</b> <ul style="list-style-type: none"> <li>● 1 piece of User's Compact Disk</li> <li>● 1 piece of AC power Cord</li> <li>● 1 pieces of data cable (RS-232C)</li> <li>● 1 pieces of data cable (Print cable)</li> <li>● 1 pieces of data cable (USB cable)</li> <li>● 1 set of Blade Holder Assembly (Installed in tool carriage of the cutting plotter )</li> <li>● 1 piece of Blade (Installed in Blade Holder)</li> <li>● 1 piece of Safe Blade</li> <li>● 1 piece of Cutting Pad</li> <li>● 1 piece of Tweezers</li> <li>● 1 piece of Promise Card</li> </ul>			<b>1</b>

### 1.3 Product Features

The following are the main features of the Expert Pro series cutting plotters:

- Tri-port connectivity provides you with greater flexibility.
- Up to 400-gram cutting force.
- Up to 600mm/per second cutting speed.
- Guaranty 5-meter tracking.
- User-friendly, multi-language control panel

## 1.4 Appearance of Expert Pro

### 1.4.1 The Front View (Figure 1-1)

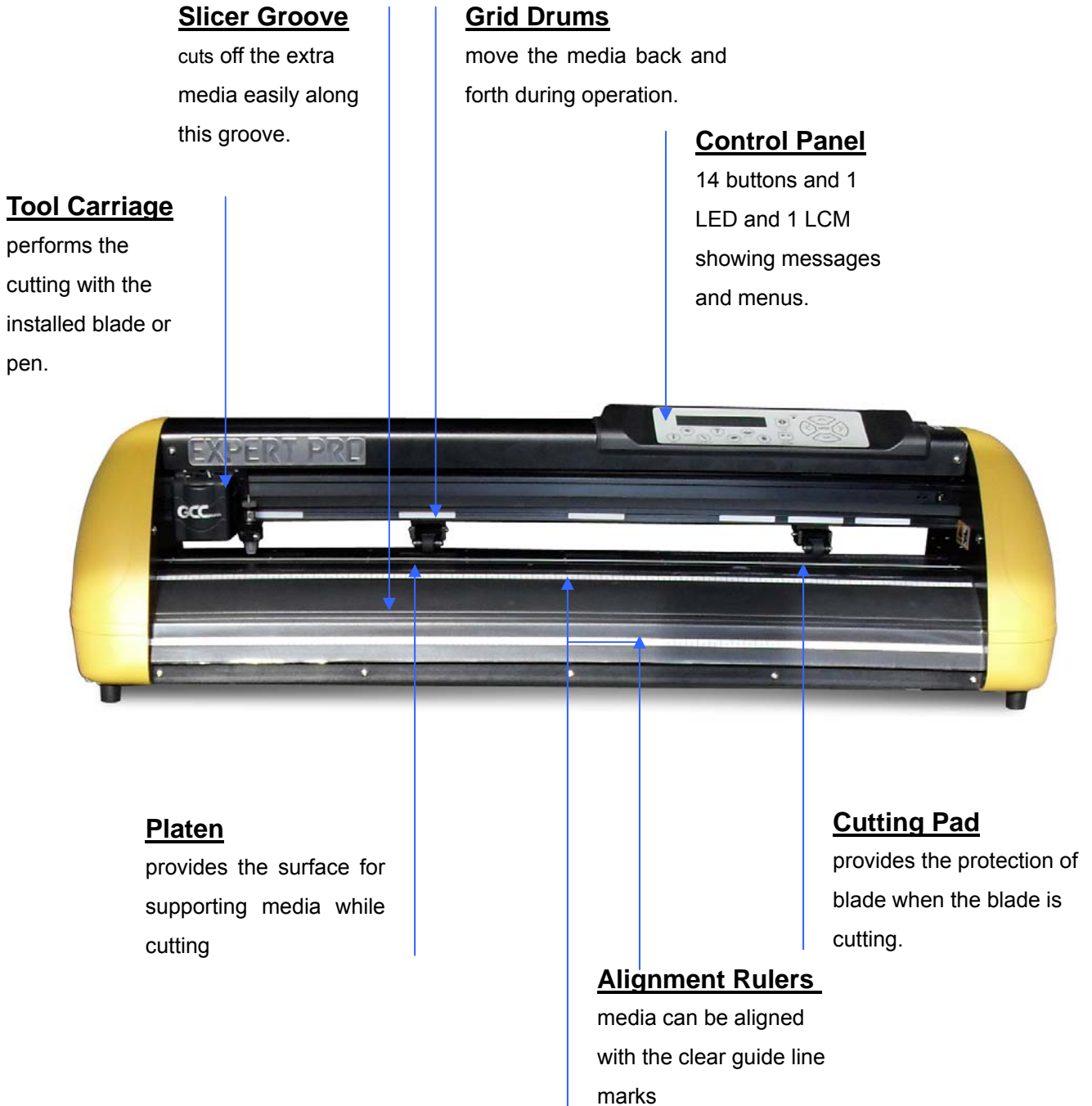

Figure 1-1

### 1.4.2 The Back View (Figure 1-2)

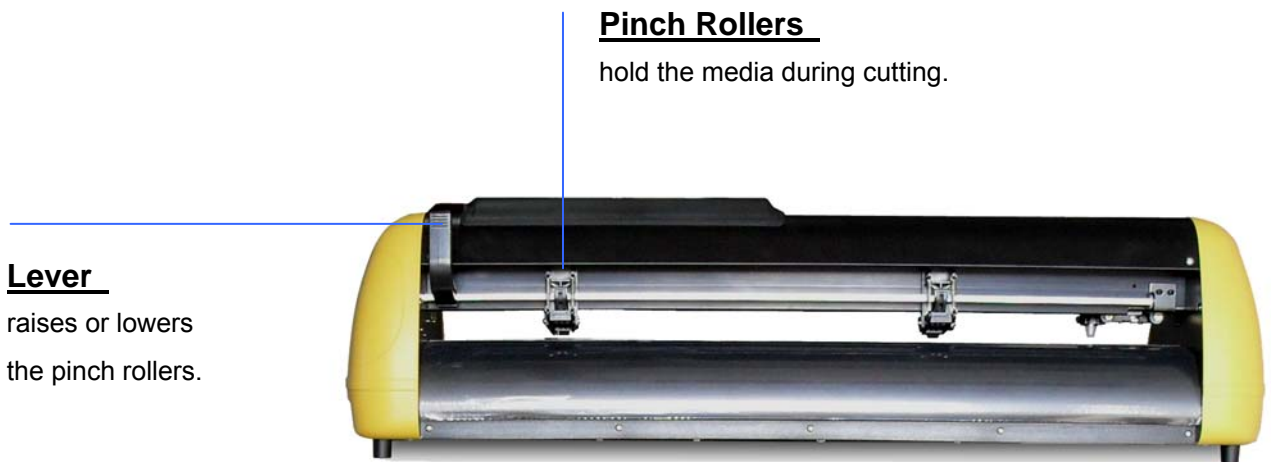
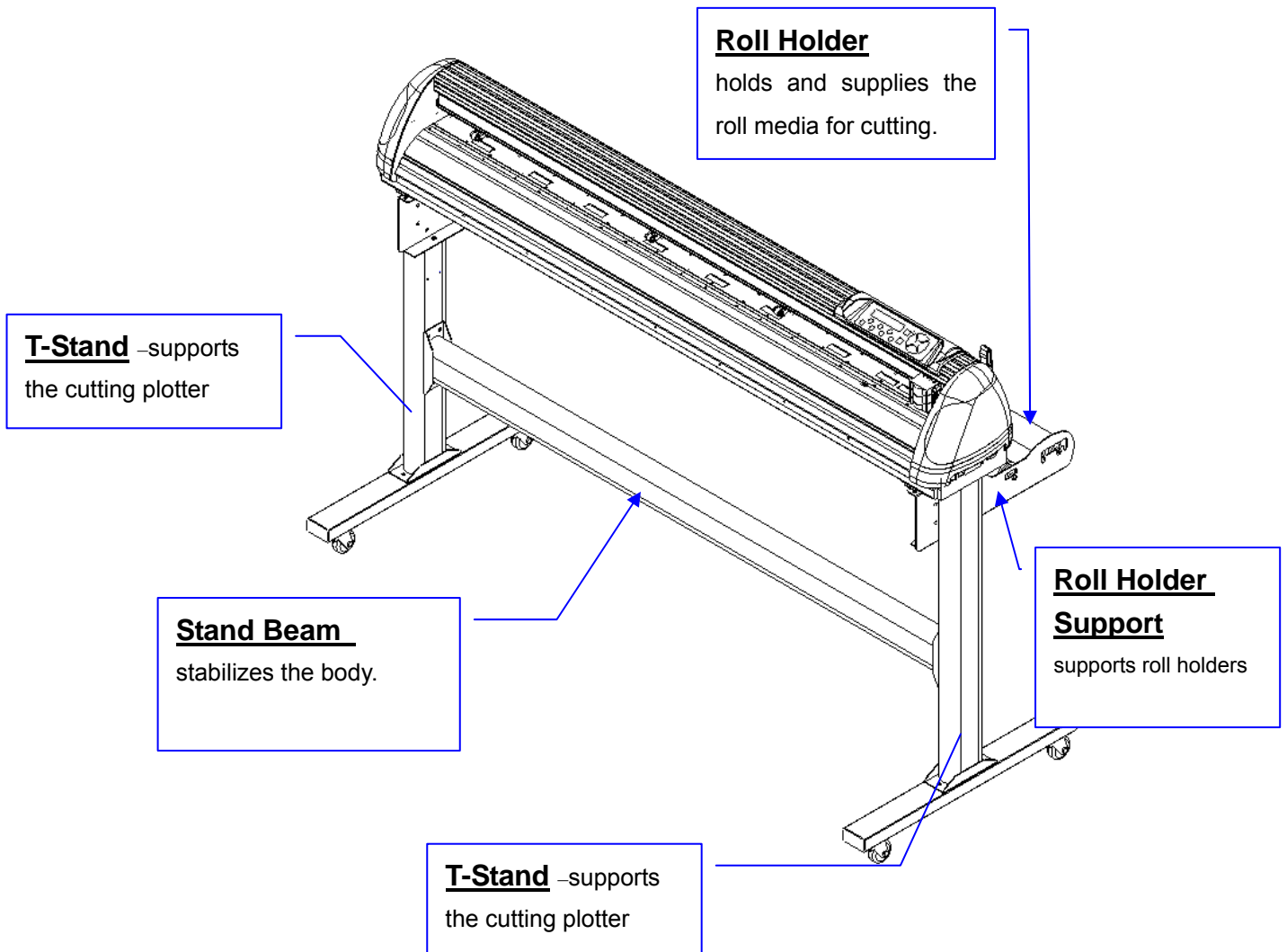

Figure 1-2

### 1.4.3 The Whole View (Figure 1-3)

\*\* The Expert Pro model comes with a standard stand



### 1.4.4 The Left-hand Side of Expert Pro (Figure 1-4)

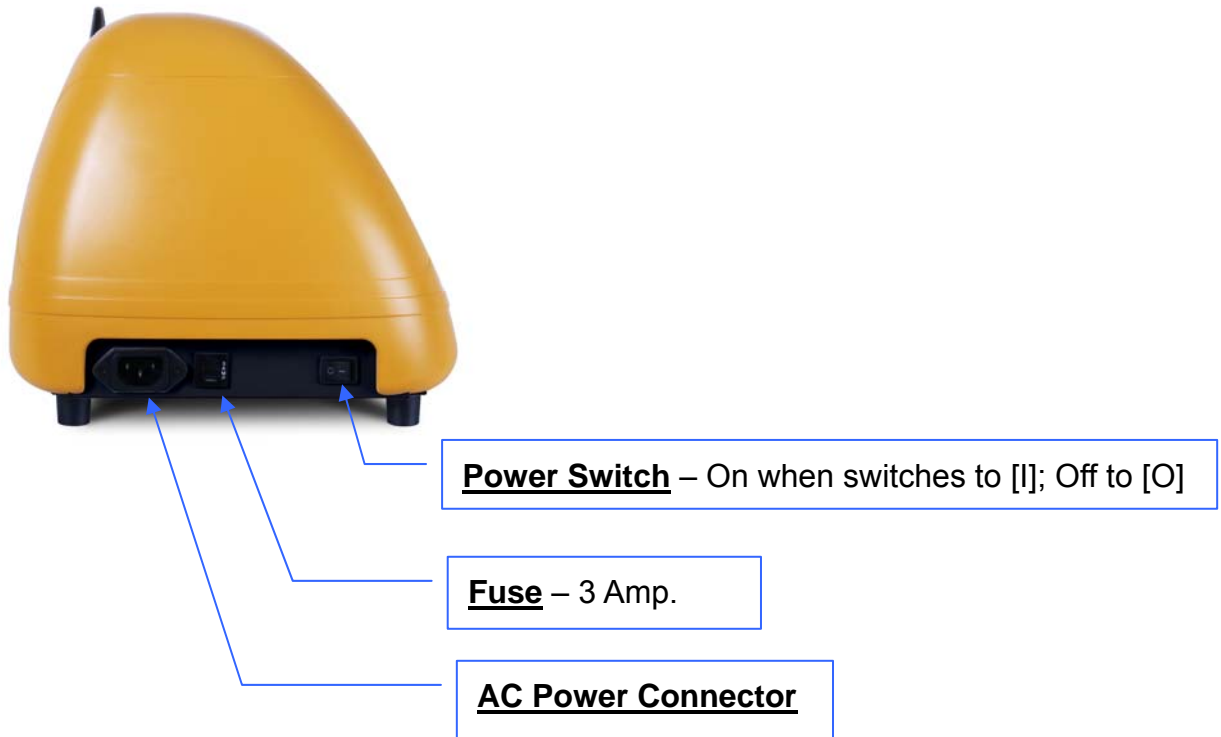

Figure 1-4

### 1.4.5 The Right-hand Side of Expert Pro (Figure 1-5)

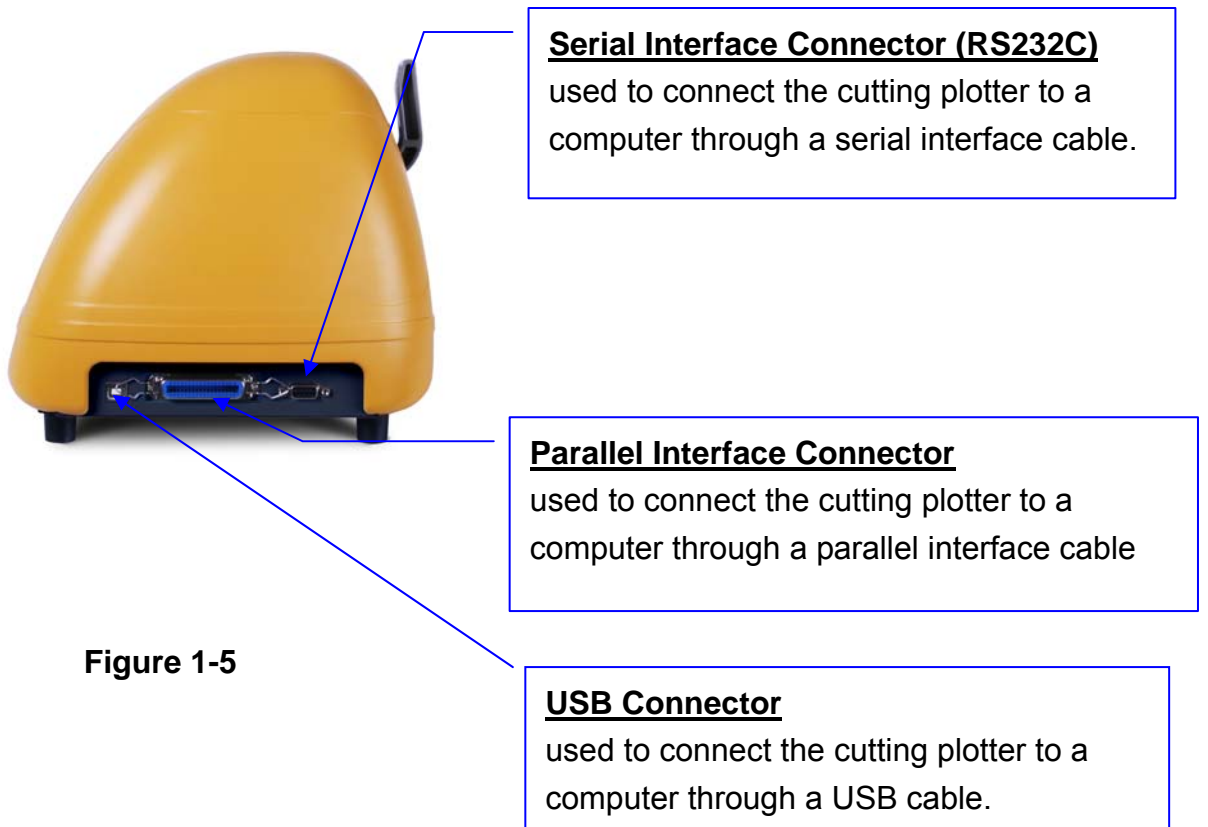

Figure 1-5

## Chapter 2 Installation

### 2.1 Precaution

#### Notice 1

---

- ❖ Carefully handle the cutter to prevent any injuries.
  - ❖ Make sure the power switch is off before installing the cutting plotter.
- 

#### Notice 2 A proper place for installation the cutting plotter

---

Please select a proper location that meets the following conditions.

- ❖ The machine can be approached easily from any direction.
  - ❖ Keep at least 60 cm space in front and behind the machine.
  - ❖ Make sure the cutter is placed on a flat, level and sturdy surface
  - ❖ The operation temperature should be between 15°C to 30°C (60 °F ~ 86°F) in the workshop.
  - ❖ The relative humidity of the working environment should be between 25% to 75%.
  - ❖ Protecting the machine from dust and air current.
  - ❖ Preventing the machine from direct sunlight.
- 

#### Notice 3 Connecting the Power Supply

---

Check the plug of the power cord to see if it matches the wall outlet. If not, please contact your dealer.

- ❖ Insert the plug (male) into a grounded power outlet.
  - ❖ Insert the other end (female) of power cord into the AC connector of cutting plotter.
-

## 2.2 Stand & Flexible Media Support System

### 2.2.1 Stand Installation (for EP-60)

Please follow the procedures below for assembling the stand and the media support system.

**Step 1** Please examine the supplied items in the accessory box of the stand carton before you install:

#### Item List :

- 1 Left side vertical stand
- 1 Right side vertical stand
- 1 Support for left side
- 1 Support for right side
- 1 Stand Beam
- 2 Bottom Stands with wheels
- 2 Sliding brackets for paper takeup
- 1 Hex Wrench (M5)Φ4
- 28 Socket flat head screws(M6\*12L)
- 1 Installation Guide

#### Step 2

Position the Left side vertical stand perpendicularly to part ① and put the screws into the holes and tighten them to form a left side T-stand (Figure 2-1). Repeat the same steps with the Right side vertical stand.

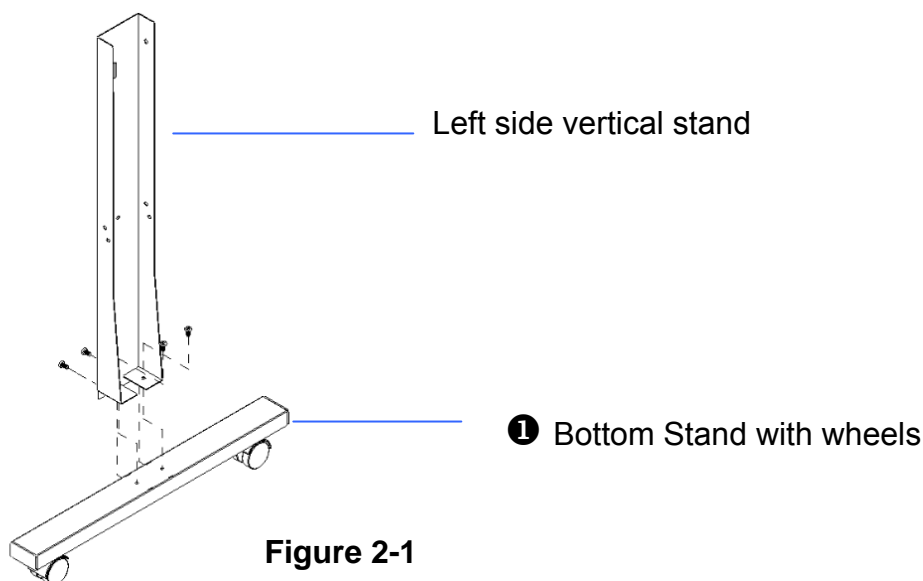

**Step 3**

Place the stand beam upright on the T-stand and put the screws into the holes but do not tighten them at this step.

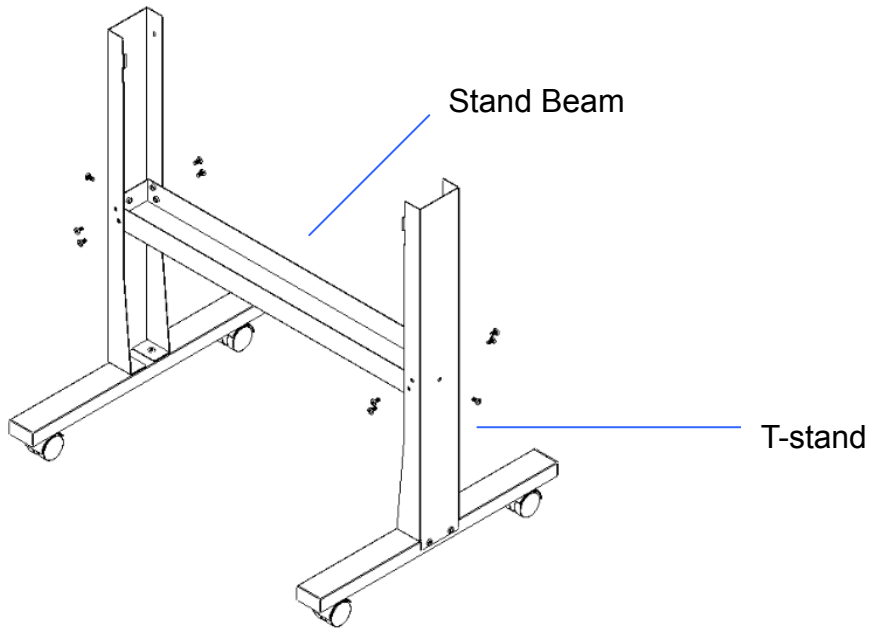
**Figure 2-2****Step 4**

Position both the left Support and right Support perpendicularly to the T-stand and put the screws into the holes and tighten them as shown in Figure 2-3.

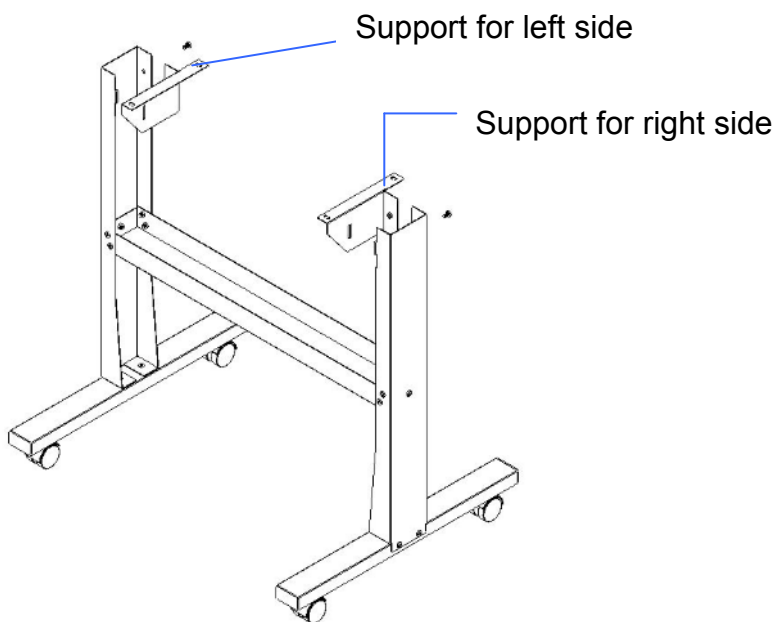
**Figure 2-3**

**Step 5**

Remove the cutting plotter from the carton. Position the stand under the plotter, and insert the screws into the holes on the bottom of the plotter but do not tighten them up as shown in Figure 2-4.

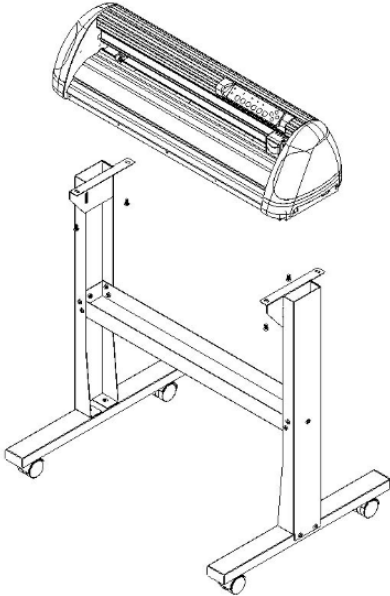
**Figure 2-4****Step 6**

Tighten the screws of step 3 and step 5. Place the sliding brackets for paper takeup onto the stand beam.

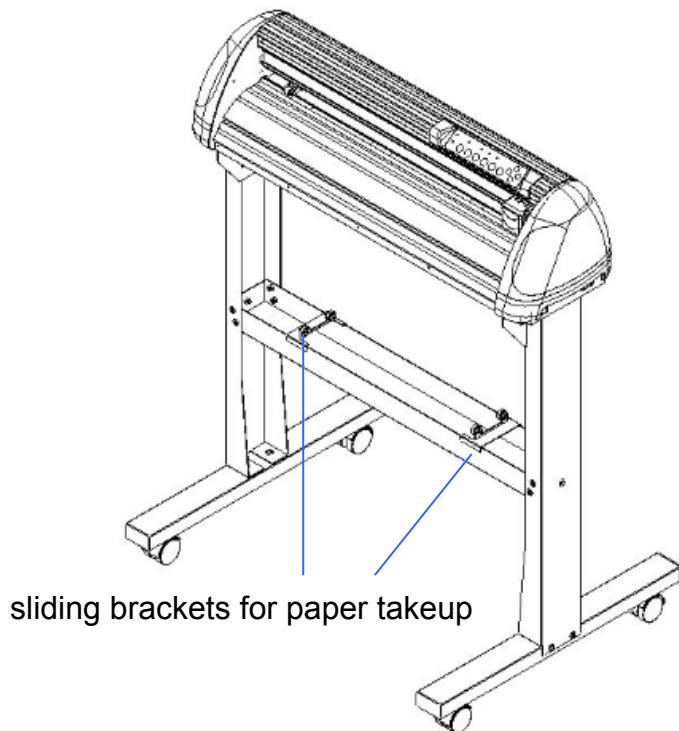
**Figure 2-5**

## 2.2.2 Stand Installation(for EP-132S)

Please follow procedure below to assemble stand and media support system.

**Step 1** Please examine supplied items in the accessory box of stand carton before you install:

### Item List :

- 2 piece of T-shape stand
- 1 piece of stand beam
- 18 pieces of M6 screws
- 1 piece of M5 L-shape hexagon screw driver
- 1 piece of Installation Guide for Stand Set

### Step 2

- Remove the plotter body and the accessories from the shipped carton.
- Place the stand beam upright on the T-stand and follow the number **1** **2** to assemble.

(See Figure 2-6 & 2-7)

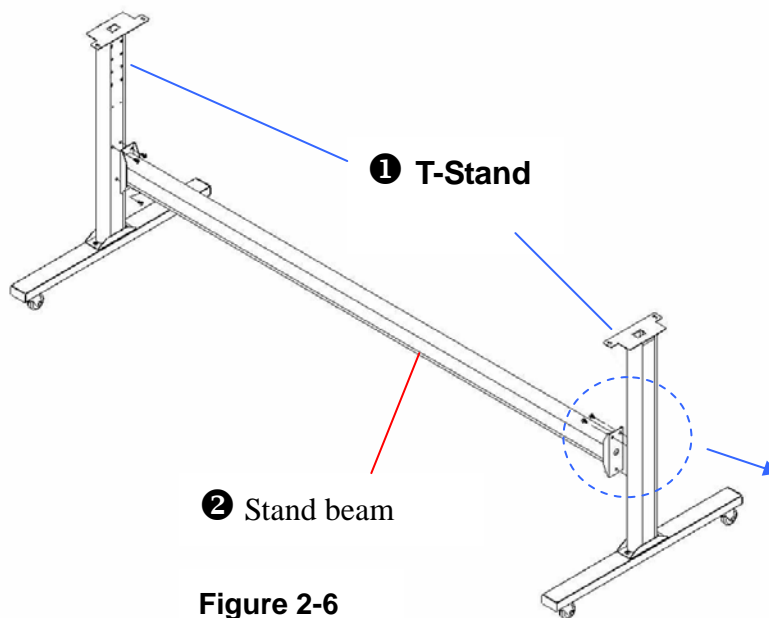

Figure 2-6



Figure 2-7

### Step 3

Position the stand beam perpendicularly to part **1** and put the screws into the holes and tighten them as Figure 2-7. Then the complete picture of stand will be like Figure 2-6.

**Step 4**

Remove the cutting plotter from the carton. Position your stand under the plotter, and then insert the screws into the holes on plotter's bottom and tighten them up as shown in Figure 2-8.

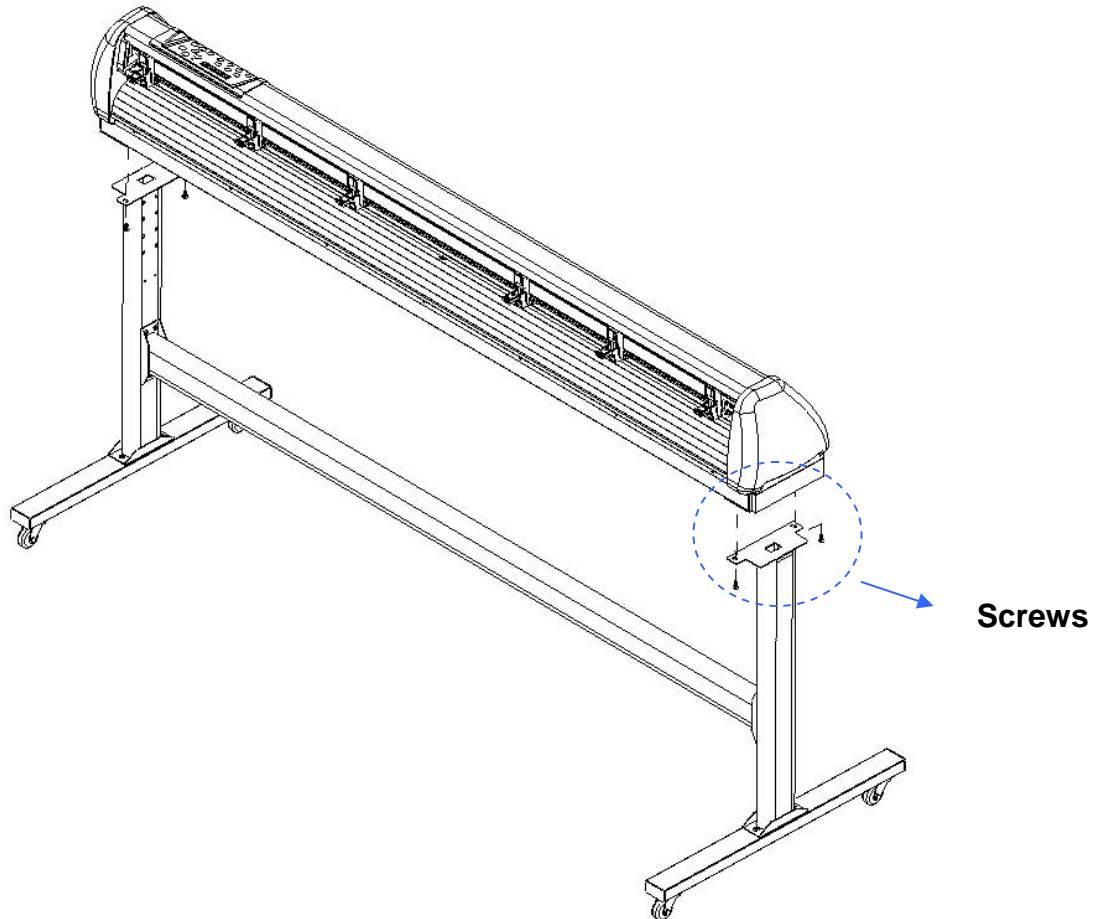

**Figure 2-8**

**Step 5**

Insert the roll holder support with the screws into the holes of the stand, and then tighten them up as shown in Figure 2-9. You could decide roll holder support's position by inserting into different holes.

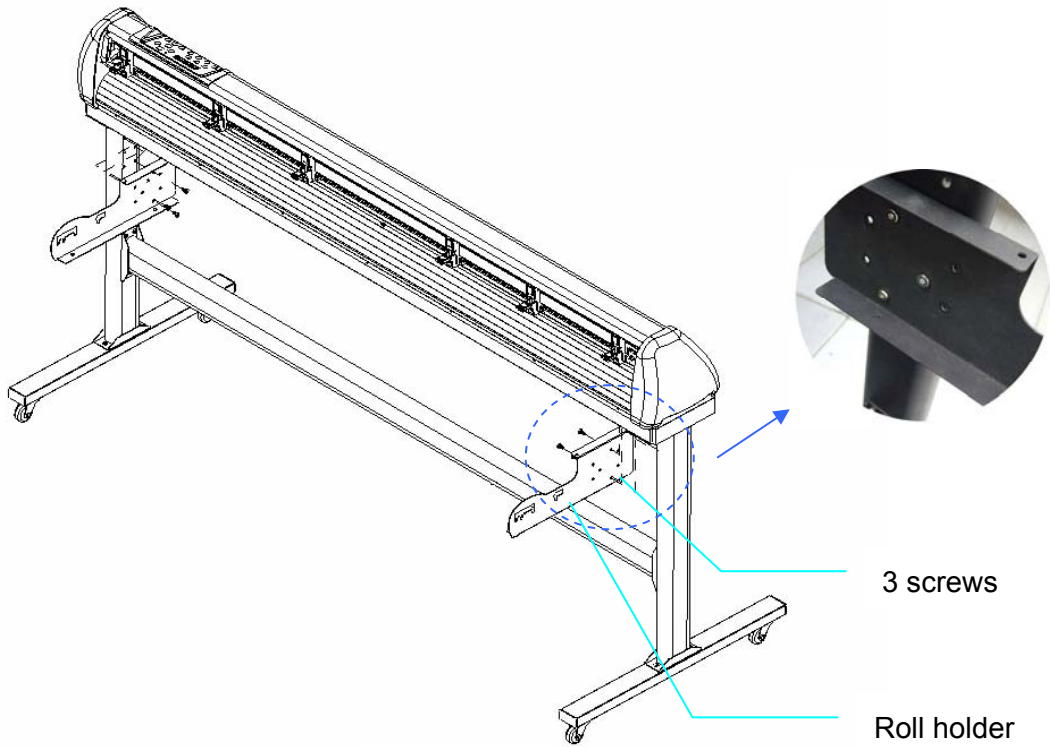

**Figure 2-9**

**Step 6**

Place two roll holders into the holes in the roll holder support. (Figure 2-10)

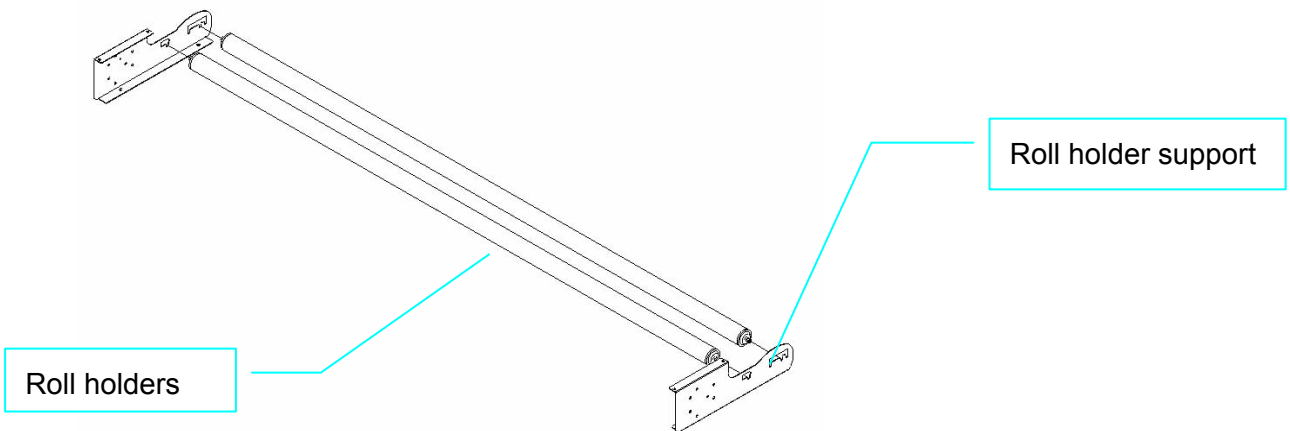

**Figure 2-10**

**Step 7**

Lastly, the complete picture will be shown like below. (Figure 2-11)

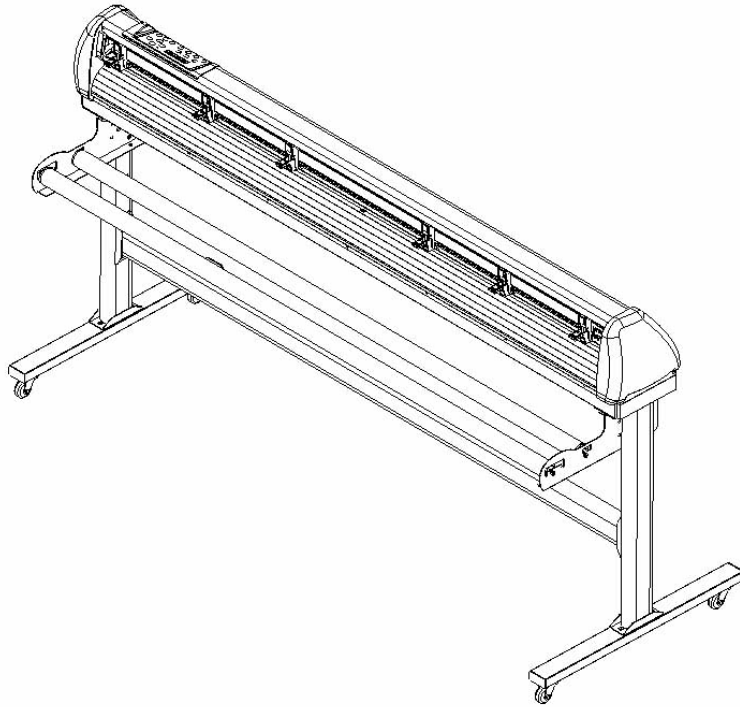

**Figure 2-11**

## 2.3 Blade Installation

### **! Caution**

Do not touch the tip of the blade by your fingers.

### **! Notice**

The blade is a consumable item, which will affect the cutting quality significantly. Please replace with a new blade when having the following situations:

1. The tip of blade is broken.
2. The cutting traces are not as good as they were.
3. Uncut area remains the same even the blade force has been raised significantly.

Figure 2-12 is the picture of the blade holder. Insert a blade into the bottom of the blade holder. Pushing the pin on the top of blade holder can remove the blade. Be sure to keep your fingers away from the blade tip.

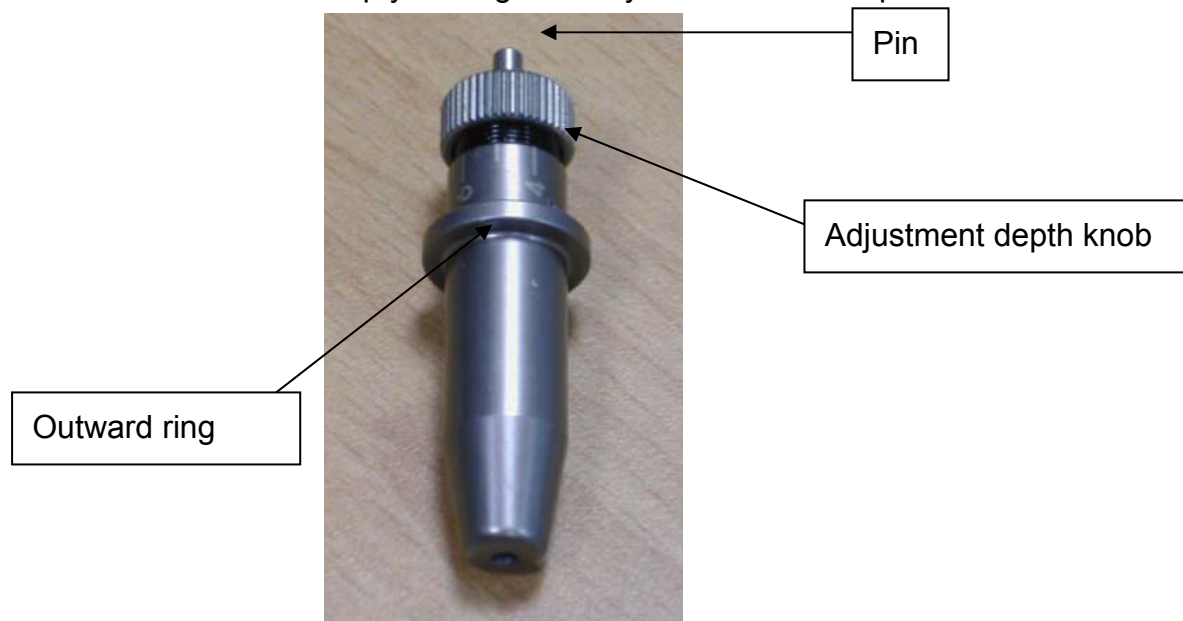

**Figure 2-12**

1. Install Blade. (Figure 2-13)



**Figure 2-13**

2. Push the blade to the bottom of the blade holder. (Figure 2-14)

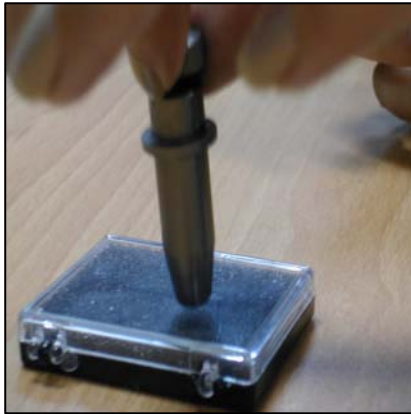

**Figure 2-14**

3. Adjust the blade tip to suitable length by rotating “Blade tip adjustment screw” clockwise or counterclockwise. (Figure 2-15)



**Figure 2-15**

**Tips:**

“The proper length” means the blade length is about 0.1mm more than film’s thickness. For example, if the thickness of film is 0.5mm, then the blade length is properly adjusted to 0.6mm and it can completely cut through the film layer without cutting through the paper backing.

4. Insert the blade holder into tool carriage. Please note the outward ring of the holder must put into the groove of carriage firmly (Figure 2-16) and lock the grip. (Figure 2-17)



**Figure 2-16**



**Figure 2-17**

5. Reverse steps mentioned above to remove the blade holder.  
6. Press the push-pin to remove the blade from the blade holder when replacing blade. (Figure 2-18)



**Figure 2-18**

## 2.4 Cable Connections

Expert Pro communicates with a computer through **USB (Universal Serial Bus)**, **Parallel port (Centronics)** or **Serial port (RS-232C)**. This chapter shows you how to connect the cutting plotter to a host computer and how to set up the computer/cutting plotter interconnection.

**!! Notice:** When USB connection is enabled, both parallel port and serial port will be disabled automatically.

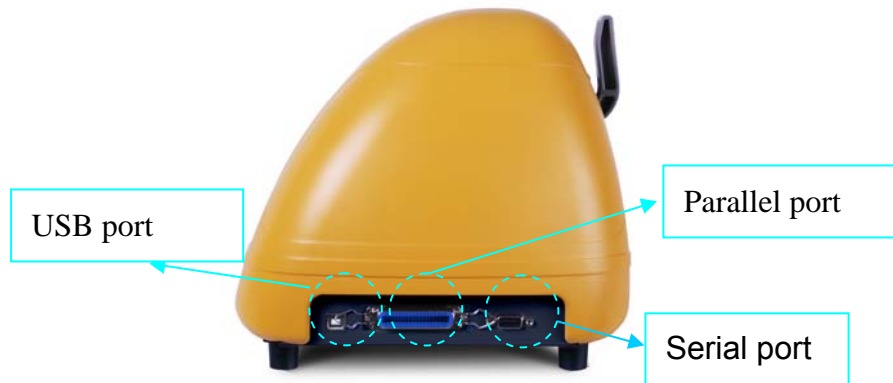

Figure 2-19

### 2.4.1 USB Interface

Expert Pro build-in USB interface is based on the Universal Serial Bus Specifications Revision 1.1. (Operation system of Windows 95, Windows NT don't support USB ).

#### ■ USB driver installation

**Caution!!**

- ✓ **If you are using Windows 2000 / XP / Vista / 7 as your operating system, make sure you log in using the "Administrator" account.**

Use the USB One-click Installation for quick driver installation. Follow the simple steps below for driver setup.

**Step 1:****Connecting your GCC cutter**

1. Connect the USB connector to the machine and then USB driver will installed automatically.

**NOTE**

Check that the USB mode option under [ MISC ] → [ USB Printer Type ] menu is set to Common USB Mode before running the installation.

**Step 2: Installing the software**

- (1) Put the installation CD into your CD-ROM. **Please make sure that the USB device is connected before you start the driver installation.**

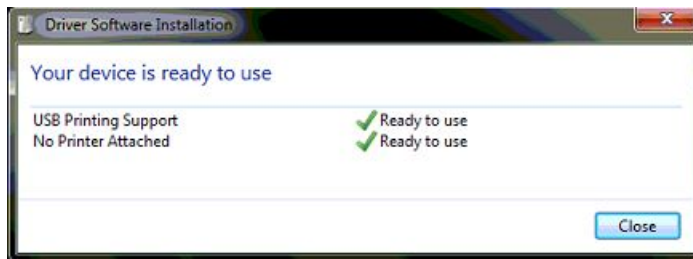

- (2) Choose the model you want to install from the driver list and click on either the 32 bit or 64 bit driver installation depending on the operating system installed on your computer to start the installation.



**NOTE**

If you use the Windows 7 / Vista 64 bit program, please note that a pop-up window will be shown upon the initial installation as shown below:

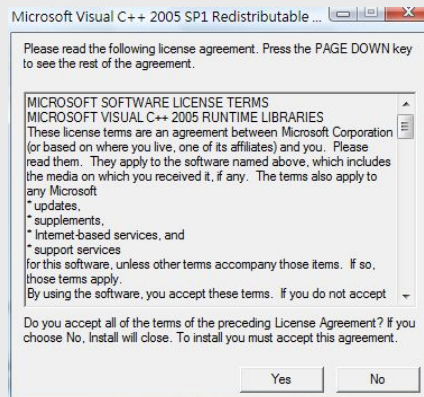

Click "Yes" to continue.

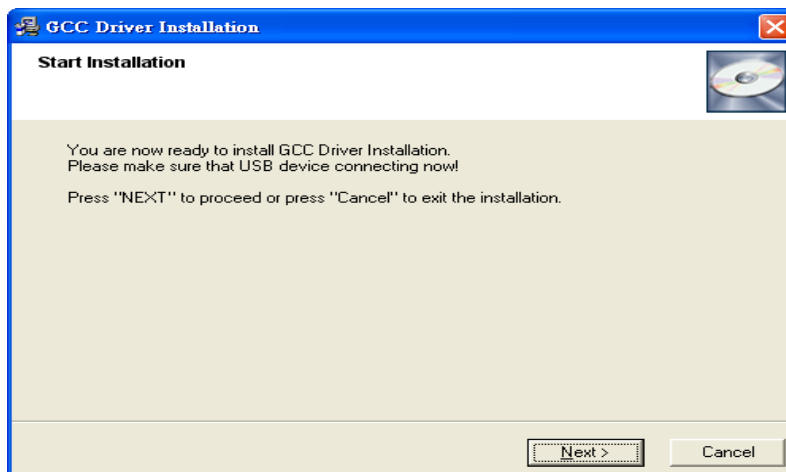

(3) Click "Next"

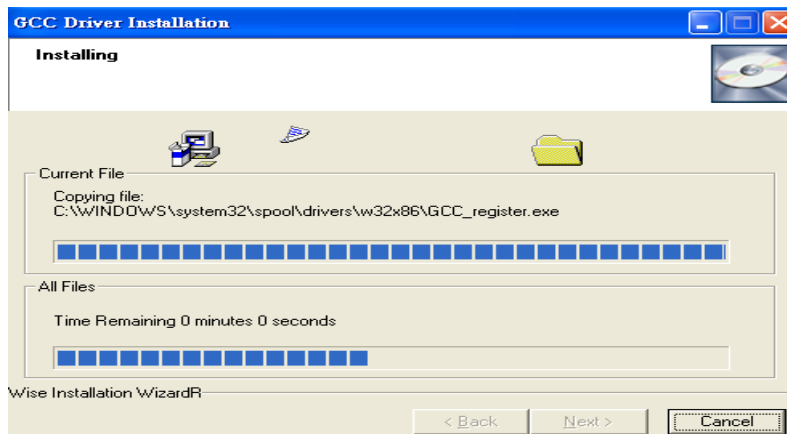

- (4) The installation will take a few minutes to complete and you will see a message below and click on “OK” upon completion. Enjoy your GCC cutter!



Note:

- (1) If the driver is being installed for a second time, the user will be prompted as to whether a second copy of the driver installation is required.



- (2) If the user selects yes, a second copy of the driver will be installed.

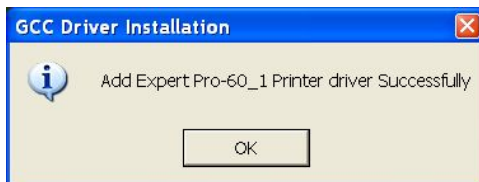

## 2.4.2 Parallel Interface

- Connecting to the Parallel (Centronics) Port
  1. Connect a parallel cable to the cutting plotter and the host computer
  2. Set up the output port **LPT1** or **LPT2** from your software package
  3. Send the data to your cutting plotter directly. Or, use DOS commands like **TYPE** or **PRINT** to output data.

**Caution!! Please turn off the plotter before plugging the print cable.**

## 2.4.3 RS-232 Interface

- Connecting to the RS-232 (Serial) Port
  1. For Personal Computer users, connect the RS-232C cable to the serial connector of the assigned serial port (COM1 or COM2) on your host computer.
  2. Set up the communication parameters (Baud Rate and Data Bits/Parity) to match the setting of software package, refer to chapter 3 – “MISC” key description.

**Caution!! Please turn off the plotter before plugging the RS-232C cable.**

## 2.4.4 Data Transmitting

There are two options to transmit the data from the computer to the cutting plotter:

### **Option 1**

With proper interface settings, the data can be transmitted from your application software package to the cutting plotters directly.

### **Option 2**

Most cutting software packages are able to emulate **HP-GL** or **HP-GL/2** commands, therefore, Use DOS commands like **TYPE** or **PRINT** to output your file. As long as the file is **HP-GL** or **HP-GL/2** format, the cutting plotter can output the data precisely.

For example, a file with **PLT** extension generated by **SignPal** can be transmitted directly to the plotter at the DOS prompt, and then be cut out. Before outputting at the DOS prompt, set up a transmission protocol between your cutting plotter and computer by a DOS command, **MODE**. Make sure that your PC has the same communication protocol as the cutter. For example:

**MODE COM2: 9600, N, 8, 1, P**

Then, use **TYPE** command to output via **COM2** if **COM2** is the assigned output port.

**TYPE filename > COM2**

*Tip:* Add the **MODE** command line to your system's **AUTOEXEC.BAT** to automatically execute **MODE** command every time you want to output your data at the DOS prompt via serial connection. However, values in a **MODE** command should comply with the related requirements of your software. Refer to DOS manual for further information.

## Chapter 3 The Control Panel

This chapter describes the button operations with the LCM menu flowcharts of Expert Pro. When the cutting plotter is ready for use as described in Chapter 1 & 2, all functions are under default parameters.

### 3.1 The LCD Panel

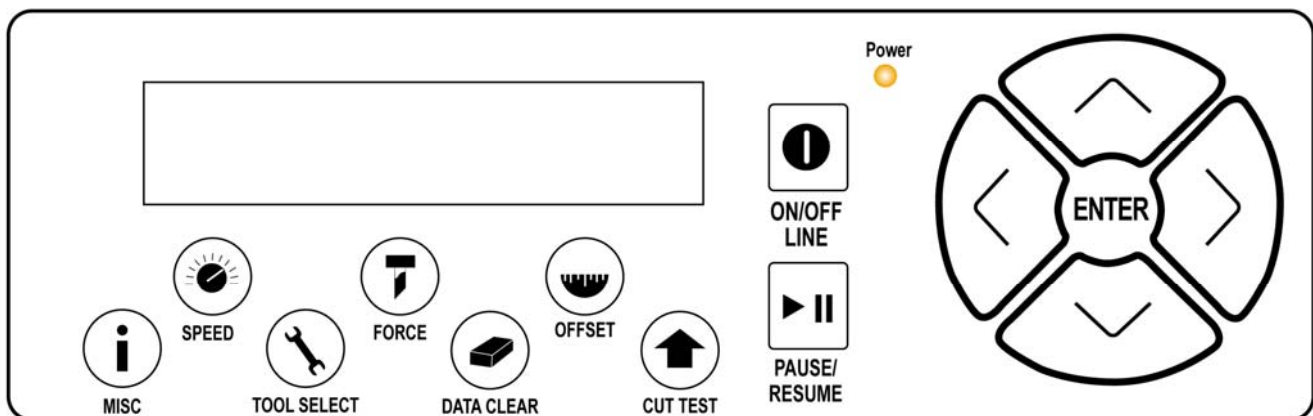

< LCD Control Panel on Expert Pro series >

Key	Function
LCD Screen	To display functions and error messages.
Power LED	To indicate the power status ( light up: power on; light off: power off )
4 Arrow Keys	To move position, select function, or change setting.
ENTER	To set item or register the immediately preceding input value.
PAUSE/RESUME	To temporarily halt cutting process or to continue
ON/OFF LINE	To switch modes, stop cutting job, or abort changes of settings.
OFFSET	To adjust the value of blade's offset.
FORCE	To adjust the value of cutting force.
SPEED	To adjust the value of cutting speed and quality.
CUT TEST	To perform cutting tests in different ways.
DATA CLEAR	To clear up buffer memory.
TOOL SELECT	To select tools.
MISC	To set up functions.

Please see details in ["3.4 Menu Items"](#)

### 3.2 Menu in On-line Mode

**Power On** Expert Pro in processing

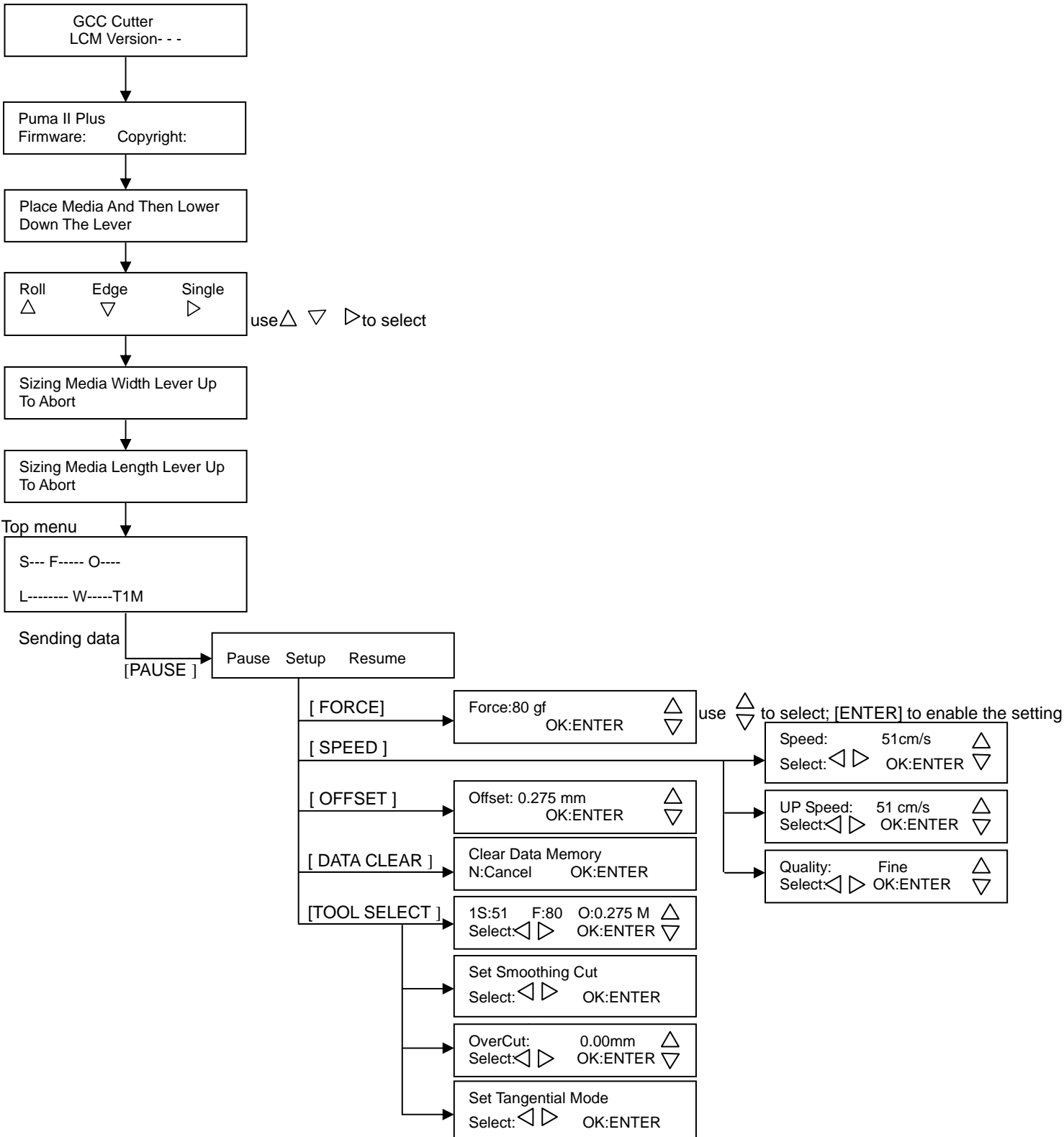

### 3.3 Menu in Off-line Mode

Press [ON/OFF LINE] to switch to the offline mode

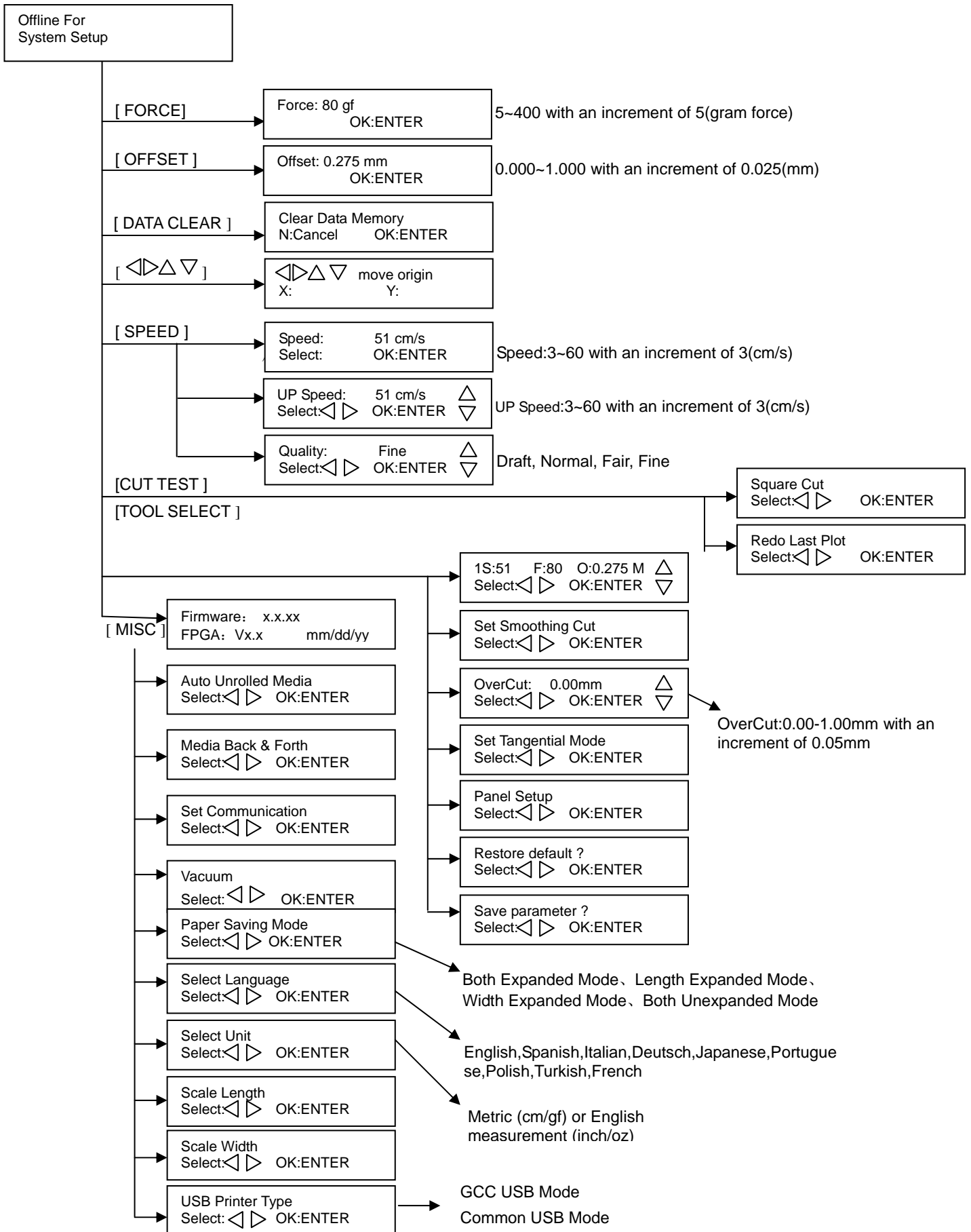

### 3.4 Menu Items

Below describes the functions of menu items

Menu or Key	Function	Setting	Default
<b>--- Media sizing ---</b>			
Roll	To measure media width.	Maximum Tracking 150 meters	
Edge	To measure media width and pull the media back till the front paper sensor open.	Maximum Tracking 150 meters	
Single	To measure media width and length.	Maximum Tracking 10 meters	
<b>--- POWER ---</b>			
	To indicate the power status.		
<b>[ Arrow Keys ]</b>			
	1. To move the tool carriage position on X or Y axis. 2. To select functions or change values of settings.		
<b>[ ENTER ]</b>			
	1. The displayed parameters will be saved automatically. 2. To set a new origin at the present tool carriage position. In "offline" mode, moving the tool carriage to desired position by [Arrow Keys], then press [ENTER] key to set a new origin. While moving with the parameters of XY-axes displayed, press [MISC] key will enable fine-tune movement; press [MISC] key again to disable the function.		
<b>[ PAUSE/RESUME ]</b>			
	To temporarily halt the cutting process. To resume the process by press [Pause/Resume] key again.		
<b>[ ONLINE/OFFLINE ]</b>			
	1. To switch between online mode and offline mode. 2. To stop the cutting job or abort the change of setting. Once press this key, the cutting job will be terminated immediately and cannot be resumed.		
<b>[ OFFSET ]</b>			
	To set or modify the distance between the blade tip and the center axis.	0.000~1.000mm	0.275mm
<b>[ FORCE ]</b>			
	To set or modify the value of tool force.	5~400gram; 5 gram/per step	80 gram
<b>[ SPEED ]</b>			
Speed	To set or modify tool speed at horizontal moving.	3~60cm/sec; 3cm/sec per step	51 cm/sec
Up Speed	To set or modify tool speed at vertical moving.	3~60cm/sec; 3cm/sec per step	51 cm/sec
Cutting Quality	To set or modify cutting quality. [Slower speeds / higher quality - Faster speeds / lower quality]  The Set Cutting Quality Page allows you to adjust and balance vector mode's quality and speed settings based on your specific job. Draft Mode offers the highest output speed,	Draft, Normal, Fair, Fine	Normal

	sacrificing quality. Whereas Quality Mode offers the highest quality, sacrificing output speed. Keep in mind that speed and quality are usually at a tradeoff.		
<b>[ CUT TEST ]</b>			
Square Cut	To perform a cutting test at present blade position. For more information, please refer to “4.3 Adjusting the Cutting Force and Offset” to adjust blade force and cutting speed.		
Redo Last Plot	Recut: To repeat the last job without re-sending the data.	1~99; 1 per step	
	Copy: To copy the last job without re-sending the data.  * 1mm gap will be auto-generated between 2 copies). * If the media length is not enough to continue, it will show below message on LCM: <div style="border: 1px solid black; padding: 5px; width: fit-content; margin: 10px auto;">O u t O f S p a c e ; # o f C o p i e s f i n i s h e d</div> * If both functions are enabled at the same time, the cutter will perform the last setting only.	1~99; 1 per step	
<b>[ DATA CLEAR ]</b>			
	To clear up buffer memory.		
<b>[ TOOL SELECT ]</b>			
Set Smoothing Cut	To enable smooth-cutting function.		Enable
Over Cut	To generate an overcut to facilitate weeding.	0.00mm-1.00mm 0.05mm/per step	0.00mm
Set Tangential Mode	To enable the emulated tangential-cutting mode for thicker media types and small letter cuts. Note: while the Offset value setting at 0.000 mm, “Set Tangential Mode” will automatically be disabled.		Disable
Panel Setup	Accept setup command: To accept commands of the Force, Speed, Cutting Quality, and Offset only via software.		
	Control panel only: To accept commands of the Force, Speed, Cutting Quality, and Offset only via control panel of the cutter.		
Restore Default	To turn all parameters of the menu items to factory-default settings.		
Save Parameter	To save pattern(s) of cutting parameters for later use.		
<b>[ MISC ]</b>			
Auto Unrolled Media	To avoid paper jam and motor crash by automatically unroll media (50cm and up) before cutting while enabled. . * Auto-unroll only effects on roll/edge media. * Using Single mode to size media will disable this function automatically. * If the length of the rolled media is less than 2 meters or the weight is light, it is recommended to set this mode disabled.		Disable





## Chapter 4 Operation

### 4.1 Media Loading

#### 4.1.1 Loading the Sheet Media

To load the media properly, please follow the procedures listed below:

Pull the lever upward to raise the pinch rollers. (Figure 4-1)

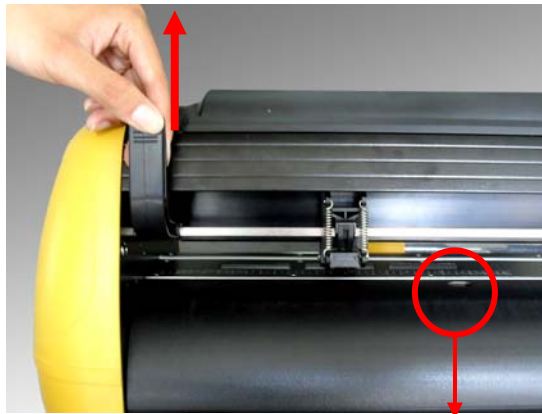

Figure 4-1 Paper sensor

Load your media on the platen and slide it under the pinch rollers from either the front side or the backside. The **alignment rulers** on the platen extension will help you to adjust the media precisely.

**Note:**

Be sure that the media must be covered by the paper sensors on the platen when loading the media. At least one of the two paper sensors should be covered. Once the media covers the sensor, the cutting plotter will size width and length of media automatically.

Then move the pinch rollers manually to the proper position. Be sure the pinch rollers must be positioned above the grid drum. The **white marks** on top trail will help you position pinch rollers when media on the platen. (Figure 4-2)

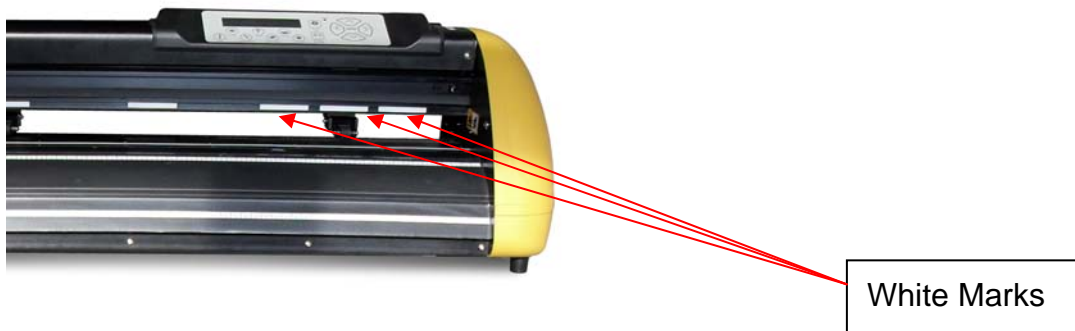

**Figure 4-2**

Push the lever downward to lower down the pinch rollers.

Turn on the power; the machine will be initialized. Then follow the instruction of LCM to measure the size of the media.

**Note:**

Move the pinch roller by applying force at the rear portion of the pinch roller support. Do not move it by holding its front rubber roller.



**Figure 4-3 correct way to move pinch rollers**

### 4.1.2 Loading the Roll Media

Firstly, put the roll media guide bushes on two roll holders. (Figure 4-4)

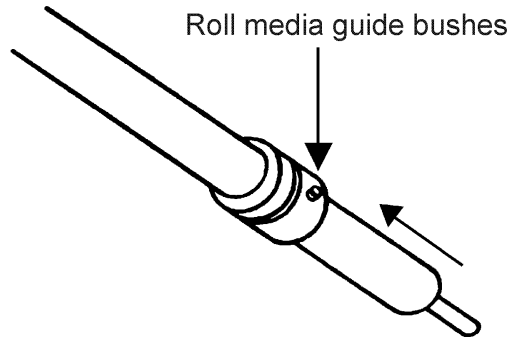

Figure 4-4

#### Option A

Insert the two roll holders into the roll media support set, and then place the roll media directly between the two roll holders. (Figure 4-5)

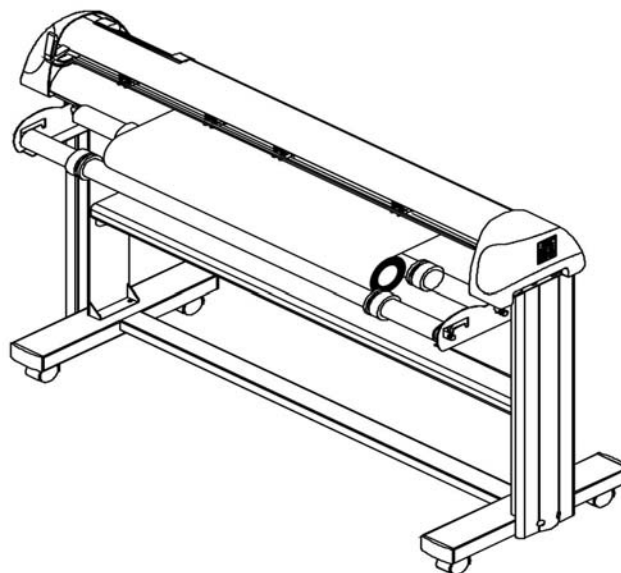
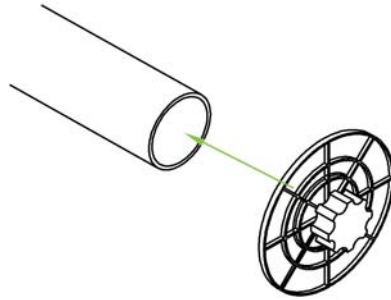

Figure 4-5

### Option B (Use the media flange)

1. Insert a roll media flange at the end of each roll media and tighten the thumbscrew until the roll media is firmly gripped. (Figure 4-6)



**Figure 4-6**

2. Then put the roll media on the roll holders. Adjust the position of the roll media ensure that the media flange is able to run in the groove of media guide bushes. (Figure 4-7)



**Figure 4-7**

(The Puma model is used in the pictures for illustration.)

3. Loading the media on the platen. After loading the roll media, flatten the media on the platen and hold the front edge of the roll media firmly.(Figure 4-8)

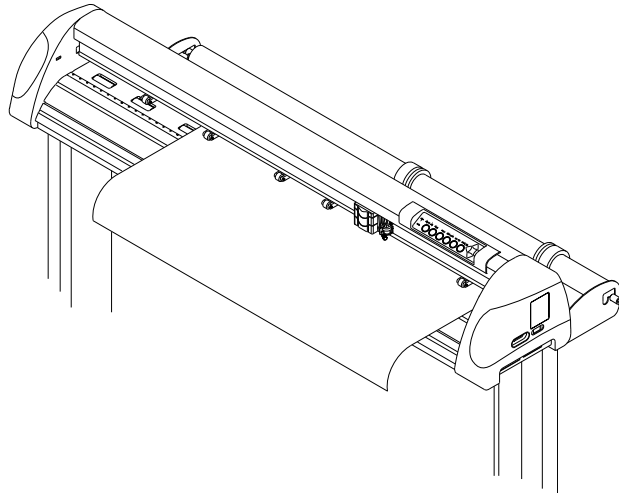

**Figure 4-8**

4. Then turn the roll downward to make an equal tension across the media. (Figure 4-9)

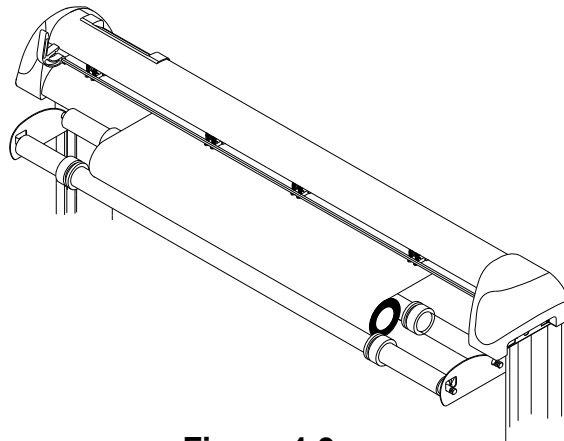
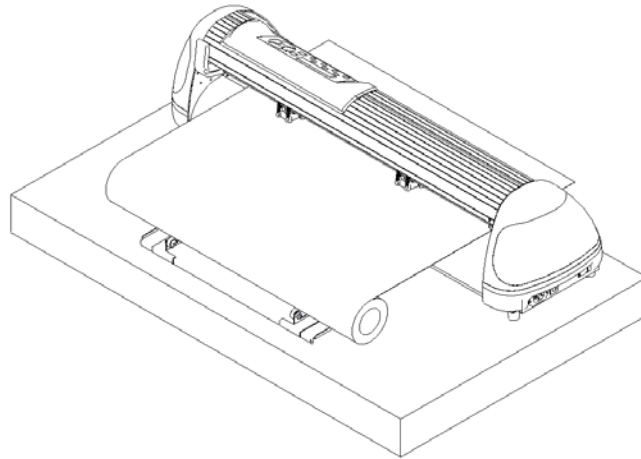

**Figure 4-9**

5. Move the pinch rollers to the precise location and be careful that the pinch rollers must be positioned above the grid drums.
6. Push the lever downward to lower down the pinch rollers.
7. Fixes roll media guide bushes on the roll holder to secure the roll media.
8. Turn on the power switch, and the tool carriage will size the media automatically. Then the cutting plotter is ready to work.

9. Unloading media: Reversing steps mentioned above to remove the media.

For the users of Expert Pro-60, you can also use the “Roll Base” (a standard accessory of Expert Pro-60) to feed a roll media. Please adjust the position of roll base to get a good cutting result. (Figure 4-10)



### 4.2 Tracking Performance

In order to achieve the best tracking performance for a long plot, please leave the margin of 0.5mm~25mm in the left and right edges of the media.(Figure 4-11)

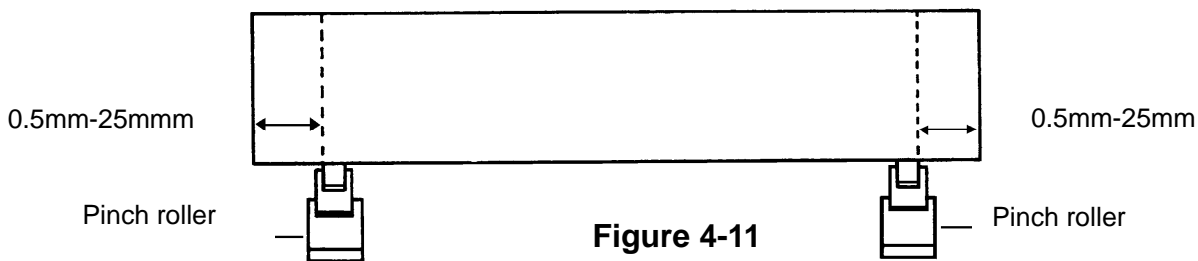

Figure 4-11

### 4.3 Cutting Force and Offset Adjustment

Before sending your designs from computer to Expert Pro for cutting, please make “Cut Test” to adjust cutting force and offset value.

The “Cut Test” should be repeated several times until the optimum settings are achieved.

Please follow procedure below to optimum the cutting force and offset settings.

#### Step1.

After sizing the media, press [CUT TEST] button to select the “Square Cut”, and press [ENTER KEY] to confirm.

The default cutting force and offset value of the cutting test are 80gf and 0.275mm respectively.

#### Step2.

Press [ARROW KEY] to move the tool carriage to the position where you would like to cut. Then, press the [ENTER KEY] to make a “Cut Test”.

Note: At the same time, the new origin is also set at the cut test position.

#### Step3.

When the “Cut Test” is completed, a pattern appears (please refer to Figure 4-12). Peel off the pattern to see if it can be easily separated from the media base. If the output result is good, the cutting force is set appropriately. If not or it cut through the back paper of media, press [FORCE KEY] to adjust the tool force until an optimum force is obtained.

#### Step4.

If the pattern appears to be BB or CC layout (see Figure 4-12), press [OFFSET KEY] to adjust the offset value until AA pattern is shown.

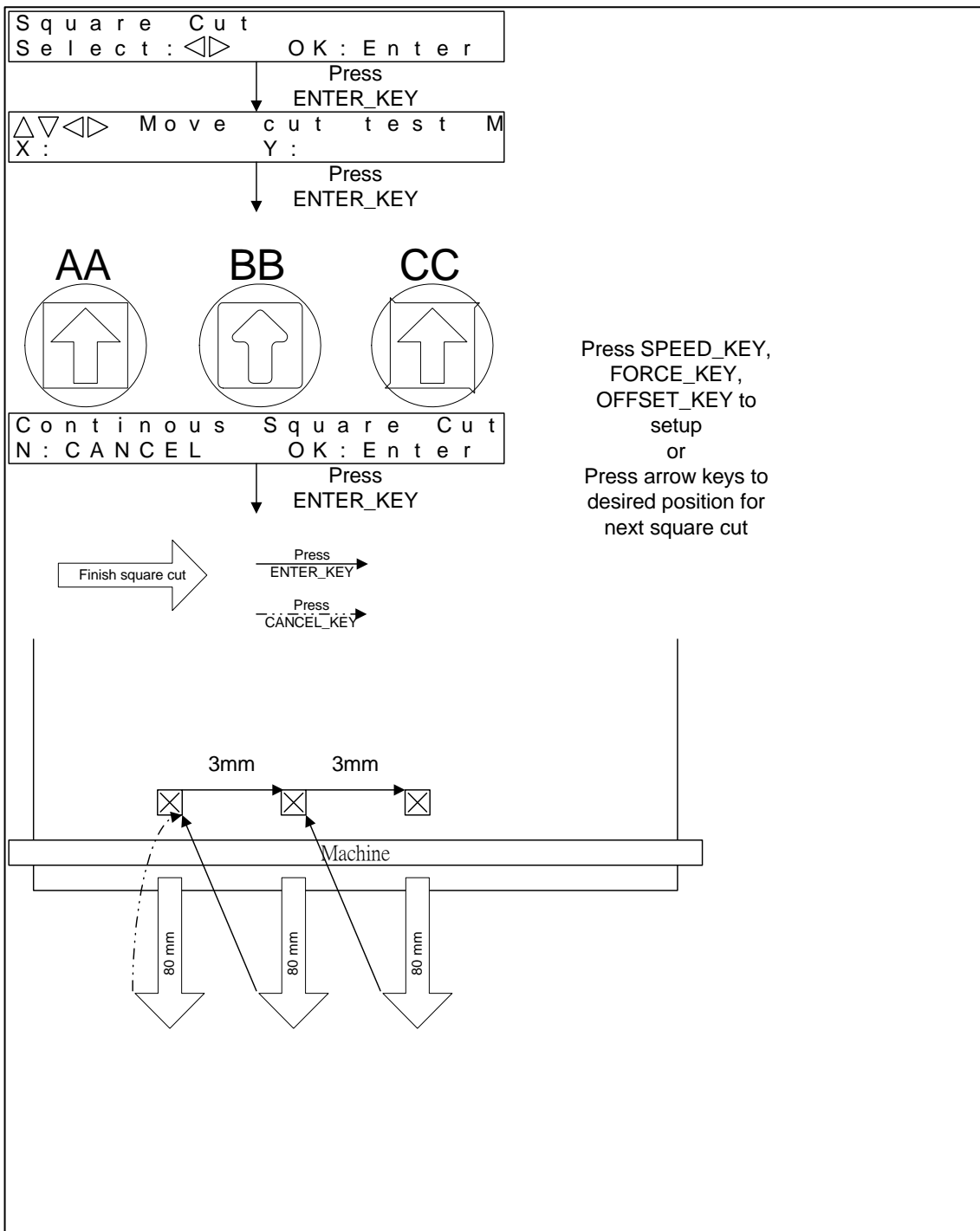

Figure 4-12

#### 4.4 When Completing the Cutting Job

After completing the cutting job, raise the sheet-loading lever, and then remove the material. You can also cut off the finished job by the Safe Blade (a standard accessory) along the knife guide. (Figure 4-13)



**Figure 4-13**

## Chapter 5 Basic Maintenance

This chapter explains the basic maintenance (i.e. cleaning the cutting plotter) required for the cutting plotter. Except for the below mentioned, all other maintenance must be performed by a qualified service technician.

### 5.1 Cleaning the Cutting Plotter

In order to keep the cutting plotter under good condition and best performance, you need to clean the machine properly and regularly.

#### Precaution in Cleaning



- ✧ Unplug the cutting plotter before cleaning
- ✧ Never use **solvents, abrasive cleaners or strong detergents** for cleaning. They may damage the surface of the cutting plotter and the moving parts.

#### Recommended Methods

- ✧ Gently wipe the cutting plotter surface with a lint-free cloth. If necessary, clean with a damp cloth or an alcohol-immersed cloth. Wipe with water to rinse off any residue and dry with a soft, lint-free cloth.
- ✧ Wipe all dust and dirt from the tool carriage rails.
- ✧ Use a vacuum cleaner to empty any accumulated dirt and media residue beneath the pinch roller housing.
- ✧ Clean the platen, paper sensors and pinch rollers with a damp cloth or an alcohol-immersed cloth, and dry with a soft, lint-free cloth.
- ✧ Wipe dust and dirt from the stand.

## 5.2 Cleaning the Grid Drum

- ❖ Turn off the cutting plotter, and move the tool carriage away from the area needed to be cleaned.
- ❖ Raise the pinch rollers and move them away from the grid drum for cleaning.
- ❖ Use a bristle brush (a toothbrush is acceptable) to remove dust from the drum surface. Rotate the drum manually while cleaning. Refer to Figure 6-1

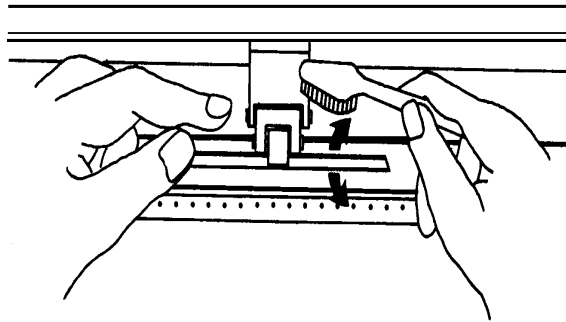

Figure 6-1

## 5.3 Cleaning the Pinch Rollers

If the pinch rollers need a thorough cleaning, use a lint-free cloth or cotton swab to wipe away the accumulated dust from the rubber portion of the pinch rollers. To prevent the pinch rollers from rotating while cleaning, use finger to hold the pinch rollers not to rotate.

If needed to remove the embedded or persistent dust, use the lint-free cloth or cotton swab moistened with rubbing alcohol.

**Note:** The daily maintenance of your cutting plotter is very important. Be sure to clean up the grid drum and pinch rollers regularly for better cutting accuracy and output quality.

## Chapter 6 Trouble Shooting

This chapter is to help you correct some common problems you may come across. Prior to getting into the details of this chapter, please be sure that your application environment is compatible with the cutting plotter.

**Note:**

Before having your cutting plotter serviced, please make sure that the malfunction is in your cutting plotter, not the result of an interface problem or a malfunction in your computer or a software problem.



*Why is the cutting plotter not functioning?*

### **Possible Causes:**

#### **6.1 Non-Operational Problems**

Check the following first:

- Does the AC power cord plug in properly?
- Does the AC power cord connected to the power connector properly?
- Does the power LED still illuminate?

#### **Solutions:**

If the LCM is able to display the message, the cutting plotter should be in a normal condition. Switch off the cutting plotter and turn it on again to see if the problem still existing.

If the LCM is not able to display any message, contact the technician from your dealer.

## 6.2 Operational Problems

Some mechanical problems or failure during operation will cause some problems. The error messages shown on the LCM present the problem first, and followed by recommended actions. If the problem still exists after the recommended actions have been done, have your cutting plotter serviced.

**Error, Check Media  
Or Drum or X Motor**

This message indicates that there might be a problem on the **X axis**. Check if the drum is working well and if the media is well loaded. Correct the problem and re-power on to reboot system.

**Error, Check Media  
Or Y Motor**

This message indicates that there might be an obstruction to carriage relating to a problem on the **Y axis**. Correct the problem and re-power on to reboot system.

**Error, Check Carriage  
Sensor or VC Motor**

This message indicates that the blade up/down sensor malfunction. Re-power on to re-boot system. If the problem still exists, find a serviceman.

**Graph Was Clipped.  
Data In Buffer**

This message indicates that the cutting exceeds the cutting limit. Reload larger media or re-scale the plot to a smaller size; then press the key followed by the display of LCM to continue.

### 6.3 Cutting Plotter/Computer Communication Problems

The messages showed below present problems in relation to cutting plotter/computer communication.

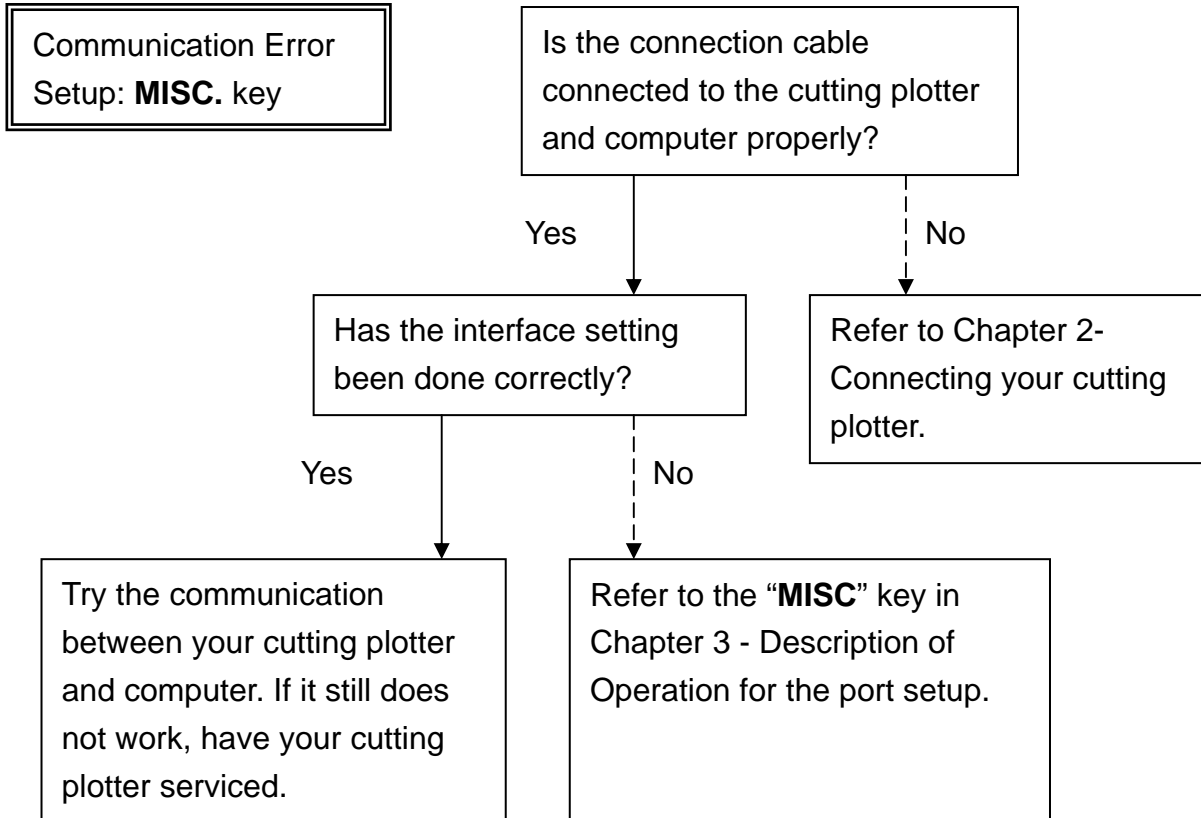

**Note:**

The computer also needs to set up compatible communication parameters to the cutting plotter set up.

HP-GL/2 Cmd. Error

If your cutting plotter can not recognize the HP-GL/2 or HP-GL commands, please check the HP-GL/2 or HP-GL commands applied to your cutting plotter are used properly.

## 6.4 Software Problems

Check the following first:

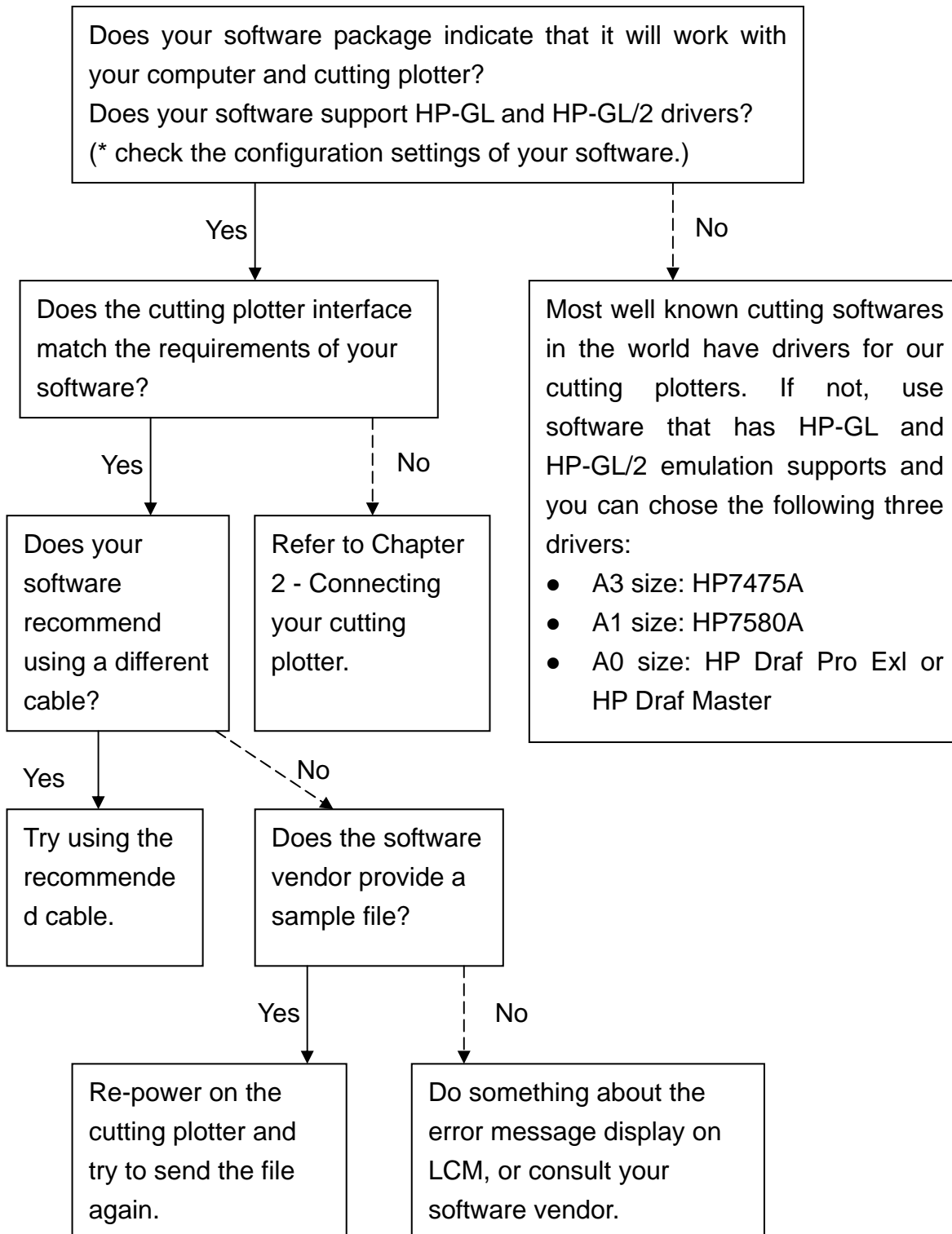

## 6.5 Cutting Quality Problems

**Note:** The daily maintenance of your cutting plotter is very important. Be sure to clean up the grid drum and pinch rollers regularly for better cutting accuracy and output quality.

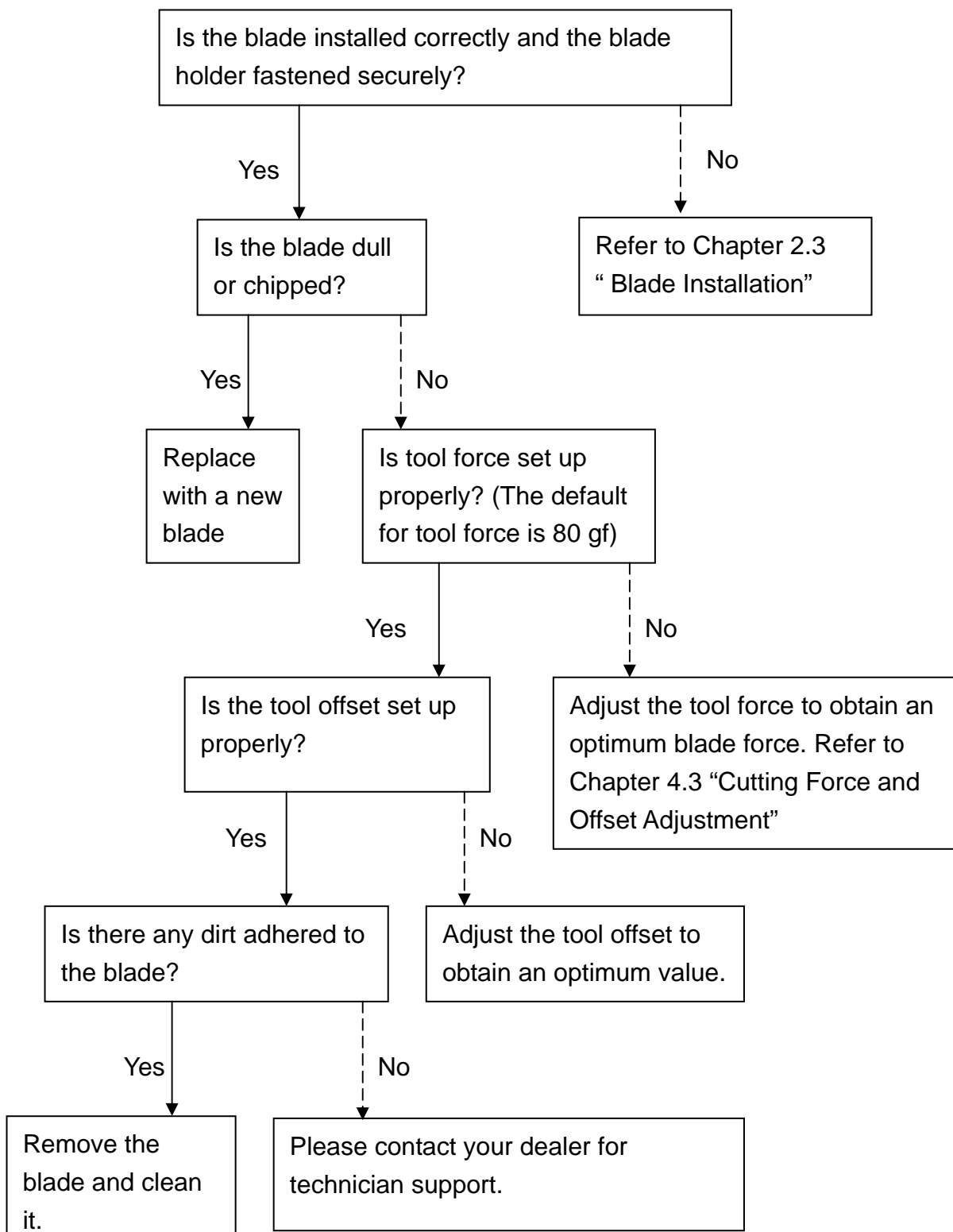





## Expert Pro Specification

Model Name/No.	EP-60	EP-132S
Operational Method	Roller-Type	
Max. Cutting Width	590mm(23.23in)	1300mm(51.18in)
Max. Cutting Length	50m(164ft)	
Max. Media Loading Width	719mm(28.3in)	1470mm(57.87in)
Min. Media Loading Width	70mm(2.76")	
Acceptable Material Thickness	0.8mm (0.03 in)	
Number of Pinch Rollers	2	4
Motor Drive	DC Servo Control	
Cutting Force	400 g	
Max. Cutting Speed	Up to 600 mm /sec (23.62 ips)	
Offset	0~1.0 mm (with an increase of 0.025 mm)	
Mechanical Resolution	0.009 mm (0.00035")	
Software Resolution	0.025 mm (0.00098")	
Repeatability	±0.1mm up to 5 meters (* certified media)	
Memory Buffer	4MB	
Interfaces	USB 1.1 & Parallel (Centronics) & Serial (RS-232C)	
Type of Command	HP-GL, HP-GL/2	
Control Panel	LCD (20 digits x 2 lines), 14 Keys, 1 Power LED	
Dimension (HxWxD) mm	220x 879x258 8.67 x34.61x10.16in	1065 x 1632 x 620 (including stand) 41.93 x62.25x24.41in
Net Weight	13kg / 28.6lb	53 kg / 116.4 lb
Stand	Standard	Standard
Power Supply	AC 100-240V, 50~60 Hz (auto switching)	
Power Consumption	Max.110watts	
Environment Temperature	15°C~30°C / 60°F~86°F (operating)	
Environment Humidity	25%~ 75% relative humidity (operating)	

- The specification and data sheet may vary with different materials used. In order to obtain the best output quality, please maintain the machine regularly and properly.
- GCC reserves the right to change the specifications at any time without notice.

# Blade Specification

20200159G	For cutting thick fluorescent and reflective vinyl. Also for cutting detailed work in standard vinyl.
	The blade is 45° with <b>Red Cap</b> (5-unit package), 0.25 mm offset
	
26500058G	For cutting reflective vinyl, cardboard, sandblast, flock, and stencil sharp edge.
	The blade is 60° with <b>Green Cap</b> , 0.50 mm blade offset
	
26500059G	For cutting thin sandblast mask and stencil with friction feed or sprocket feed machine.
	The blade is 60° with <b>Blue Cap</b> , 0.25 mm blade offset
	
26500060G	For Cutting small text and fine detail. Sharp blade with smallest offset.
	The blade is 0.175 mm blade offset with <b>Black Cap</b>
	

# About the Tool

Frequently used terms related to the cutting blade and the plotting pen.

OFFSET is the distance that the blade tip is displaced from the centerline of the blade.

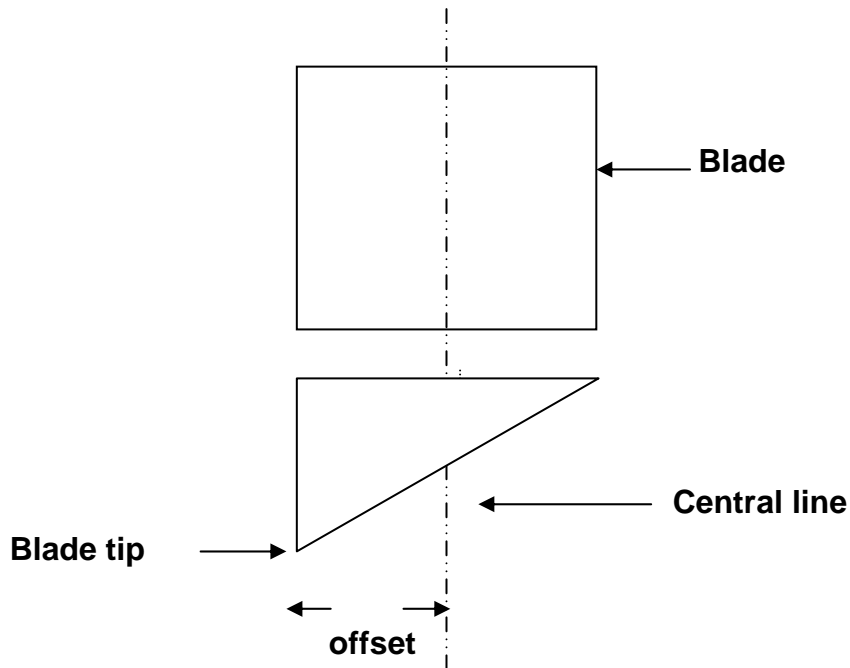

## Protrusion Length of the Blade

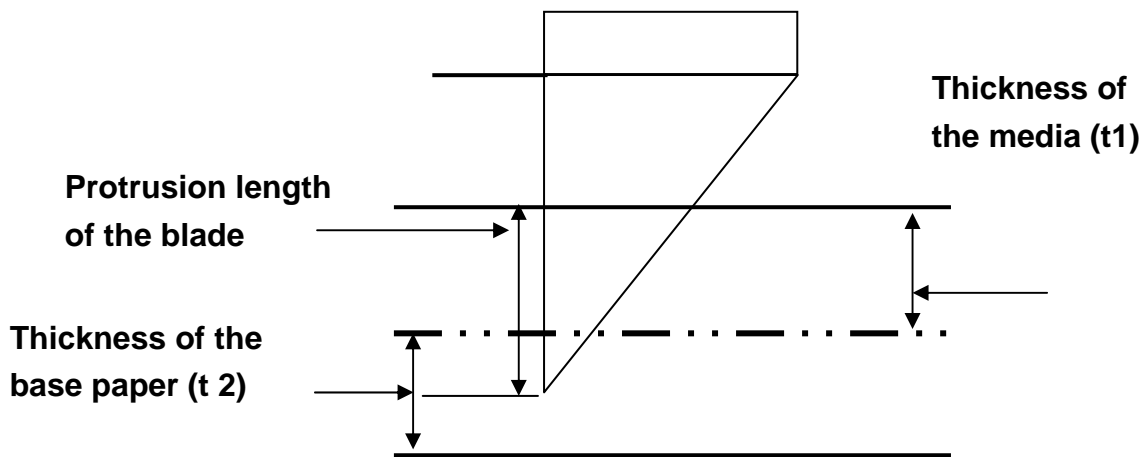

Length of protrusion =  $t_1 + t_2 / 2$ , but for your convenience you may just make it about 0.3mm ~ 0.5mm beyond the blade holder tip.